



**TF1100-EP**  
**Transit Time Ultrasonic Heat Meter**  
**Portable**

Operation & Maintenance

Manual

REV 3/2016

# CONTENTS

<b>PART-1 INTRODUCTION .....</b>	<b>1</b>
1.1 GENERAL .....	1
1.2 PRINCIPLE OF MEASUREMENT .....	1
1.3 APPLICATIONS .....	3
1.4 FEATURES .....	3
1.5 SPECIFICATIONS .....	4
1.6 PARTS IDENTIFICATION .....	5
<b>PART-2 TRANSDUCER INSTALLATION .....</b>	<b>6</b>
2.1 GENERAL .....	6
2.2 MOUNTING LOCATION .....	6
2.3 TRANSDUCER SPACING .....	7
2.4 TRANSDUCER MOUNTING .....	9
2.5 TRANSDUCER MOUNTING INSPECTION AND COUPLANT APPLICATION .....	14
<b>PART-3 START OPERATING INSTRUCTIONS .....</b>	<b>15</b>
3.1 POWER ON .....	15
3.2 KEYPAD FUNCTIONS .....	15
3.3 KEYPAD OPERATION .....	16
3.4 TF1100 WINDOW DESCRIPTIONS .....	17
3.5 PIPE PARAMETER ENTRY SHORTCUTS .....	18
3.6 INSTALLATION CHECKUP .....	19
<b>PART-4 WINDOWS DISPLAY EXPLANATIONS .....</b>	<b>21</b>
<b>PART-5 ENERGY FUNCTION .....</b>	<b>31</b>
<b>5.1 INTRODUCTION .....</b>	<b>31</b>
<b>5.2 WIRING CONNECTION .....</b>	<b>31</b>
<b>5.3 ENERGY CALCULATION .....</b>	<b>31</b>
<b>5.4 TEMPERATURE RANGE .....</b>	<b>32</b>
<b>PART-6 TEMPERATURE SENSOR INSTALLATION .....</b>	<b>33</b>
6.1 PT1000 TEMPERATURE SENSOR .....	33
6.2 TEMPERATURE SENSOR INSTALATION .....	33
(a) 6.2.1 CLAMP-ON TEMPERATURE SENSOR .....	33
(b) 6.2.2 INSERTION TEMPERATURE SENSOR .....	33
<b>PART-7 HOW TO USE MENU FUNCTIONS .....</b>	<b>35</b>
7.1 HOW TO JUDGE WHETHER THE INSTRUMENT WORKS PROPERLY .....	35
7.2 HOW TO JUDGE THE LIQUID FLOWING DIRECTION .....	35
7.3 HOW TO RESET THE DEFAULT SETUPS .....	35
7.4 HOW TO STABILIZE THE FLOW .....	35
7.5 HOW TO USE THE ZERO-CUTOFF FUNCTION .....	36
7.6 HOW TO SETUP A ZERO POINT CALIBRATION .....	36

7.7 HOW TO USE SCALE FACTOR .....	36
7.8 HOW TO USE THE OPERATION LOCKER.....	37
7.9 HOW TO USE THE 4~20M A OUTPUT .....	37
7.10 HOW TO USE THE FLOW RATE FREQUENCY OUTPUT? .....	37
7.11 HOW TO USE RELAY OUTPUT .....	38
7.12 HOW TO SET THE DATE AND TIMER.....	38
7.13 ON/OFF NET TOTALIZER.....	39
7.14 UNITS OPTIONS .....	39
7.15 LCD BACKLIT OPT IONS .....	39
7.16 USE MENU WINDOWS FOR TRANSDUCER MOUNTING INSPECTION .....	39
<b>PART-8 TROUBLESHOOTING AND FAQ.....</b>	<b>41</b>
8.1 TROUBLESHOOTING.....	41
8.2 FREQUENTLY ASKED QUESTIONS AND ANSWERS .....	43
<b>PART-9 WARRANTY AND SERVICE.....</b>	<b>45</b>
9.1 WARRANTY .....	45
9.2 SERVICE .....	45
<b>APPENDIX 1 TRANSDUCER GUIDE RAIL INSTALLATION.....</b>	<b>46</b>
<b>APPENDIX 2 HIGH TEMPERTURE TRANSDUCER GUIDE RAIL INSTALLATION</b> 错误! 未定义书签。	
<b>APPENDIX 3 FUILD CHARACTERISTIC (SOUND SPEED).....</b>	<b>49</b>
1. FLUID PROPERTIES.....	49
2. WATER SOUND SPEED.....	51
3. PIPE MATERIAL SOUND SPEED TABLE.....	52
<b>APPENDIX 4 TF1100 COMMUNICATIONS PROTOCOL.....</b>	<b>53</b>
1. OVERVIEW.....	53
2. SERIAL PORT DEFINITIONS.....	53
3. RS232 COMMUNICATION PROTOCOL AND THE USE .....	53
4. RS485 COMMUNICATION PROTOCOL AND THE USE .....	57
5. KEY CODE.....	60
<b>APPENDIX 5 MODBUS-RTU COMMUNICATIONS PROTOCOL.....</b>	<b>62</b>
<b>APPENDIX 6 DATA LOGGER AND ANALYSE SOFTWARE USAGE .....</b>	<b>63</b>

## PART-1 INTRODUCTION

### 1.1 GENERAL

It is the engineers and technicians' hope to measure the flow on the non-invasive pipeline reliably. Series TF1100 are state-of-the-art universal transit-time ultrasonic flow meters, fit to measure flow of full pipe line, providing a measuring system with unsurpassed accuracy, versatility, ease of installation and dependability. Although designed primarily for cleaner liquids, the flow meter is tolerant of liquids with the small amount of air bubbles or suspended solids found in most industrial environments.

### 1.2 PRINCIPLE OF MEASUREMENT

The TF1100 ultrasonic flow meter is designed to measure the fluid velocity of liquid within a closed pipe. The transducers are a non-invasive, clamp-on type, which will provide benefits of non-fouling operation and easy installation.

The TF1100 transit time flow meter utilizes two transducers that function as both ultrasonic transmitters and receivers. The transducers are clamped on the outside of a closed pipe at a specific distance from each other. The transducers can be mounted in V-method where the sound transverses the pipe twice, or W-method where the sound transverses the pipe four times, or in Z-method where the transducers are mounted on opposite sides of the pipe and the sound crosses the pipe once. This selection of the mounting method depends on pipe and liquid characteristics. The flow meter operates by alternately transmitting and receiving a frequency modulated burst of sound energy between the two transducers and measuring the transit time that it takes for sound to travel between the two transducers. The difference between the transit-time is directly and exactly related to the velocity of the liquid in the pipe, as shown in Figure 1.

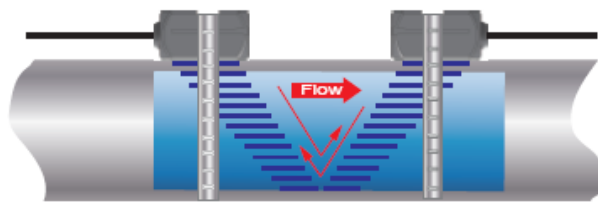

Figure 1

$$V_f = Kdt / TL$$

Where:  $V_f$  Liquid velocity  
 $K$  Constant  
 $dt$  Difference in time of flight  
 $TL$  Average Transit Time

When measuring temperature, the two temperature sensors of Pt1000 clamp on the pipeline or insert in the pipe, and get two temperature values.

The value of energy is indicated / measured based on the following mathematical model:

$$Q = \int_{V1}^{V2} k(t1 - t2)dV$$

Where: Q – Quantity of heat given up

V – Volume of liquid passed

k – Heat coefficient, is a function of the properties of the heat-conveying liquid at the relevant temperatures and pressure

t1 – Inlet temperature of liquid

t2 – Outlet temperature of liquid

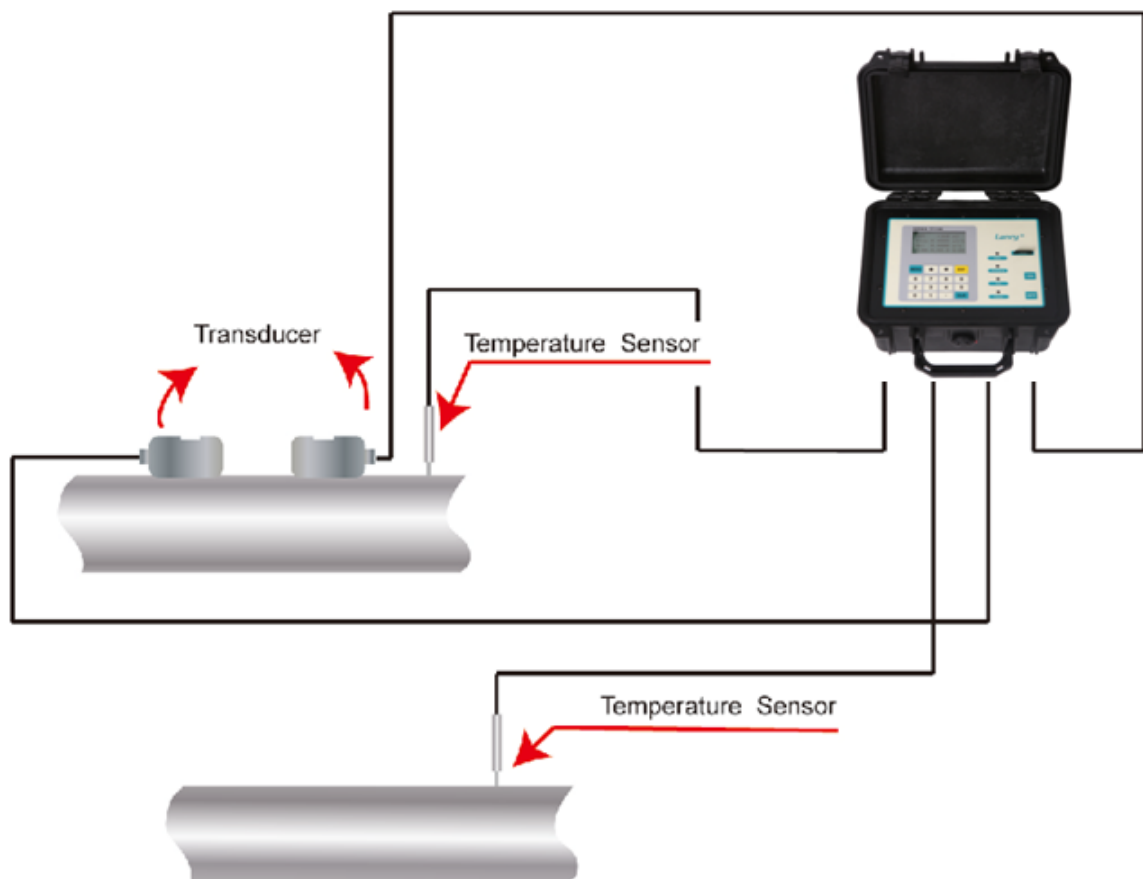

### 1.3 APPLICATIONS

1. Water, sewage (with low particle content) and sea water
2. Water supply and drainage water
3. Process liquids; Liquors
4. Milk, yoghurt milk
5. Gasoline kerosene diesel oil
6. Power plant
7. The flow patrolling and examining
8. Metallurgy, Laboratory
9. Energy-conservation, economize on water
10. Food and medicine
- 11 Heat measures, Heat balance
- 12 On-the-spot check-up, standard, the data are judged, Pipeline leak detection

### 1.4 FEATURES

- 40-hour battery (rechargeable), back-lit 4 lines display all integrated into a rugged, watertight enclosure.
- Digital cross-correlation technology
- Since the sensors do not contact the liquid, fouling and maintenance are eliminated.
- Clear, user-friendly menu selections make TF1100 simple and convenient to use
- A pair of sensors can satisfy different materials , wide different pipe diameters
- Built-in large capacity memory and USB data download function.
- The heat measurement function by configuring with paired Pt1000 temperature sensors.
- Wide bi-directional flow range and wide liquid temperature range: -35°C~200°C.
- Lightweight and easily transportable in box.

## 1.5 SPECIFICATIONS

### Specifications: Transmitter

Measurement principle	Ultrasonic transit-time difference correlation principle
Flow velocity range	0.01 to 12 m/s, bi-directional
Resolution	0.25mm/s
Repeatability	0.2% of reading
Accuracy	±1.0% of reading at rates >0.3 m/s);±0.003 m/s of reading at rates<0.3 m/s
Response time	0.5s
Sensitivity	0.003m/s
Damping of displayed value	0-99s(selectable by user)
Liquid Types Supported	Both clean and somewhat dirty liquids with turbidity <10000 ppm
Power Supply	AC: 85-265V
Enclosure type	Portable
Degree of protection	IP65 according to EN60529
Operating temperature	-10°C to +60°C
Housing material	ABS
Measurement Channels	1
Display	4 line×16 English letters LCD graphic display, backlit
Units	User Configured (English and Metric)
Rate	Rate and Velocity Display
Totalized	gallons, ft <sup>3</sup> , barrels, lbs, liters, m <sup>3</sup> ,kg
Communication	4~20mA(accuracy 0.1%),Frequency(1-9999Hz), Relay, RS232, RS485 (Modbus),Logged data
Security	Keypad lockout, system lockout
Size	270X215X175mm
Weight	3kg

### Specifications:

#### Transducer (clamp-on)

Degree of protection	IP65. IP67 or IP68 according to EN60529
Suited Liquid Temperature	Std. Temp.: -35°C~85°C for short periods up to 120°C High Temp.: -35°C~200°C for short periods up to 250°C
Pipe diameter range	20-50mm for type S, 40-1000mm for type M, 1000-6000mm for type L
Transducer Size	Type S 52(h)*28(w)*28(d)mm
	Type M 60(h)*34(w)*32(d)mm
	Type L 80(h)*40(w)*42(d)mm
Material of transducer	Aluminum for standard temp. transducer, and peek for high temp. transducer
Cable Length	Std: 5m

## 1.6 PARTS IDENTIFICATION



Transmitter



Standard Transducer



PT1000 clamp-on



PT1000 insertion



S-S Belt



Mounting rail



Couplant



OCT output cable



soft case



## PART-2 TRANSDUCER INSTALLATION

### 2.1 GENERAL

The transducers that are utilized by the Series TF1100 contain piezoelectric crystals for transmitting and receiving ultrasound signals through walls of liquid piping systems. The transducers are relatively simple and straight-forward to install, but spacing and alignment of the transducers is critical to the system's accuracy and performance. Extra care should be taken to ensure that these instructions are carefully executed.

Mounting of the clamp-on ultrasonic transit time transducers is comprised of three steps:

Selection of the optimum location on a piping system.

Entering the necessary parameters into the TF1100 keypad.

(TF1100 will calculate proper transducer spacing based on these entries (menu 25))

Pipe preparation and transducer mounting.

### 2.2 MOUNTING LOCATION

The first step in the installation process is the selection of an optimum location for the flow measurement to be made. For this to be done effectively, a basic knowledge of the piping system and its plumbing is required.

An optimum location is defined as:

**A piping system that is completely full of liquid when measurements are being taken.**

The pipe may become completely empty during a process cycle - which will result in an error code being displayed on the flow meter while the pipe is empty. Error codes will clear automatically once the pipe refills with liquid. It is not recommended to mount the transducers in an area where the pipe may become partially filled. Partially filled pipes will cause erroneous and unpredictable operation of the meter.

**A piping system that contains lengths of straight pipe such as those described in Table 2.1.** The optimum straight pipe diameter recommendations apply to pipes in both horizontal and vertical orientation. The straight runs in Table 2.1 apply to liquid velocities that are nominally 7 FPS [2.2 MPS]. As liquid velocity increases above this nominal rate, the requirement for straight pipe increases proportionally.

**Mount the transducers in an area where they will not be inadvertently bumped or disturbed during normal operation.**

**Avoid installations on downward flowing pipes** unless adequate downstream head pressure is present to overcome cavitations in the pipe.

Piping configuration And transducer position	Upstream Dimension	Downstream Dimension
	Pipe Diameters(*)	Pipe Diameters (**)
	10	5
	14	5
	24	5
	30	5
	10	5
	24	10

Table 2.1 Straight Pipe Requirement

### 2.3 TRANSDUCER SPACING

TF1100 transducers are clamped on the outside of a closed pipe **at a specific distance from each other**. The transducers can be mounted in V-mode where the sound transverses the pipe two times, W-mode where the sound transverses the pipe four times, or in Z-mode where the transducers are mounted on opposite sides of the pipe and the sound crosses the pipe once. For further details, reference pictures located under **Table 2.2**. The appropriate mounting configuration is based on pipe and liquid characteristics. Selection of the proper transducer mounting method is not entirely predictable and many times is an iterative process. **Table 2.2** contains recommended mounting configurations for common applications. These recommended configurations may need to be modified for specific applications if such things as aeration, suspended solids or poor piping conditions are present. W-mode provides the longest sound path length between the transducers - but the weakest signal strength. Z-mode provides the strongest signal strength - but has the shortest sound path length. On pipes smaller than 3 inches [75 mm], it is desirable to have a longer sound path length, so that the differential time can be measured more accurately.

**Table 2.2  
Transducer Mounting Modes**

Transducer Mount Mode	Pipe Material	Pipe Size	Liquid Composition
<b>W-Mode</b>	Plastic (all types) Carbon Steel Stainless Steel Copper Ductile Iron Cast Iron	1-6 in. (25-150 mm) 1-4 in. (25-100 mm) 1-6 in. (25-150 mm) 1-6 in. (25-150 mm) Not recommended Not recommended	Low TSS; non-aerated Low TSS; non-aerated Low TSS; non-aerated Low TSS; non-aerated
<b>V-Mode</b>	Plastic (all types) Carbon Steel Stainless Steel Copper Ductile Iron Cast Iron	6-30 in. (150-750 mm) 4-24 in. (100-600 mm) 6-30 in. (150-750 mm) 6-30 in. (150-750 mm) 3-12 in. (75-300 mm) 3-12 in. (75-300 mm)	Low TSS; non-aerated Low TSS; non-aerated Low TSS; non-aerated Low TSS; non-aerated Low TSS; non-aerated Low TSS; non-aerated
<b>Z-Mode</b>	Plastic (all types) Carbon Steel Stainless Steel Copper Ductile Iron Cast Iron	> 30 in. (> 750 mm) > 24 in. (> 600 mm) > 30 in. (> 750 mm) > 30 in. (> 750 mm) > 12 in. (> 300 mm) > 12 in. (> 300 mm)	Low TSS; non-aerated Low TSS; non-aerated Low TSS; non-aerated Low TSS; non-aerated Low TSS; non-aerated Low TSS; non-aerated

TSS = Total Suspended Solids

Transducer Mounting Modes

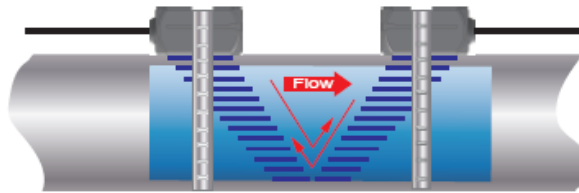

V method

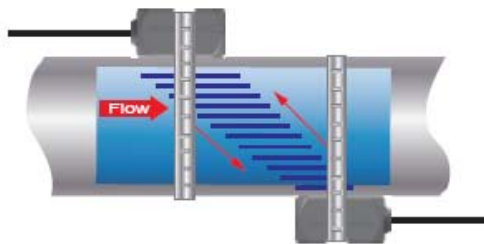

Z method

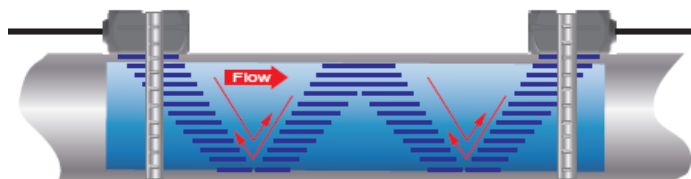

W method

The TF1100 system calculates proper transducer spacing by utilizing piping and liquid information entered by the user.

The following information is required before programming the instrument. Note that much of the data relating to material sound speed, viscosity and specific gravity are preprogrammed into the TF1100 flow meter. This data only needs to be modified if it is known that a particular liquid data varies from the reference value. Refer to Part 3 of this manual for instructions on entering configuration data into the TF1100 flow meter via the meter keypad. Transducer mounting configuration. See Table 2.2

1. Pipe Outer Diameter)
2. Pipe wall thickness
3. Pipe material
4. Pipe sound speed
5. Pipe relative roughness
6. Pipe line thickness
7. Pipe line material
8. Pipe line sound speed
9. Fluid type
10. Fluid sound speed

Nominal values for these parameters are included within the TF1100 operating system. The nominal values may be used as they appear or may be modified if exact system values are known.

After entering the data listed above, the TF1100 will calculate proper transducer spacing for the particular data set. This distance will be in inches if the TF1100 is configured in English units, or millimeters if configured in metric units.

## 2.4 TRANSDUCER MOUNTING

After selecting an optimum mounting location and successfully determining the proper transducer spacing, the transducers may now be mounted onto the pipe.

The transducers must be properly oriented on the pipe to provide optimum reliability and performance. On horizontal pipes, the transducers should be mounted 180 radial degrees from one another and at least 45 degrees from the top-dead-center and bottom-dead-center of the pipe. See Figure 2.1. Figure 2.1 does not apply to vertically oriented pipes. On vertical pipes the orientation does not apply.

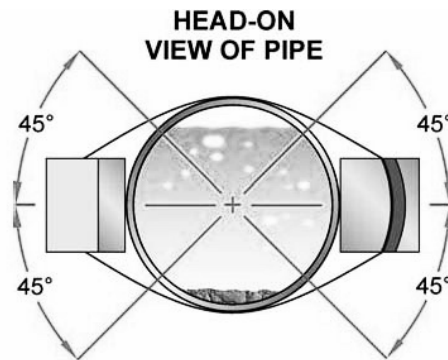

**Figure 2.1**  
**Transducer Orientation—Horizontal Pipes**

### Pipe Preparation

Before the transducers are mounted onto the pipe surface, two areas slightly larger than the flat surface of the transducer heads must be cleaned of all rust, scale and moisture. For pipes with rough surfaces, such as ductile iron pipe, it is recommended that the pipe surface be ground flat. Paint and other coatings, if not flaked or bubbled, need not be removed. Plastic pipes typically do not require surface preparation other than soap and water cleaning.

Observe Signal Strength while placing the transducers into position. Signal Strength can be displayed on Menu 90.

### V-Mode and W-Mode Installation

1. For TF1100 transducers, place a single bead of couplant, approximately 0.05inch [1.2 mm] thick, on the flat face of the transducer. Generally, silicone-based grease is used as an acoustic couplant, but any grease-like substance that is rated not to “flow” at the temperature that the pipe may operate will be acceptable.

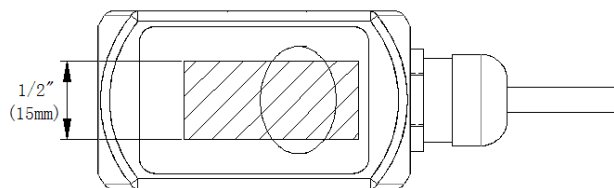
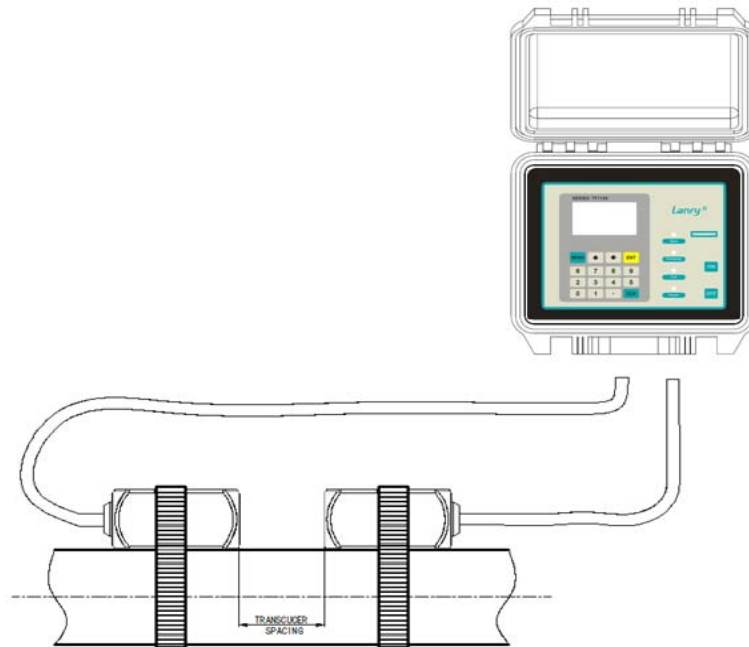

**Figure 2.2**

2. Place the upstream transducer in position and secure with a mounting strap. Straps should be placed in the arched groove on the end of the transducer. A screw is provided to help hold the transducer onto the strap. Verify that the transducer is stick to the pipe - adjust as necessary. Tighten the transducer strap securely.
3. Place the downstream transducer on the pipe at the calculated transducer spacing. See **Figure 2.3**. Using firm hand pressure, slowly move the transducer both towards and away from the upstream transducer while observing Signal Strength. Clamp the transducer at

the position where the highest Signal Strength is observed. A Signal Strength (Menu 90) between 60 and 95 is acceptable.

4. If after adjustment of the transducers the Signal Strength (Menu 90) does not rise to above 60, then an alternate transducer mounting method should be selected. If the mounting method was W-mode, then reconfigure the TF1100 for V-mode, reset the TF1100, move the downstream transducer to the new location and repeat step 3.



**Figure 2.3** Transducer position

V-Mount is the STD installation method, it is convenient and accurate, Reflective type (transducers mouthed on one side of the pipe) of installation used primarily on pipe size in the (50mm~400mm) internal diameter range attention transducer designed parallel on the centre line of installing the pipeline.

The spacing value shown on menu window M25 refers to the distance of inner spacing between the two transducers. The actual transducers spacing should be as close as possible to the spacing value. The transducer spacing is from the end of one transducer to another sensor.

The transducer mounting spacing is very important for Transit-time meters, and users need mount transducers exactly according to the spacing distance value M25 displays after users input proper parameter settings. M91 is only for reference, and just keep it within 97--103% value range.

As the above figure shows, the normal transducer spacing refers to the distance between the ends of the two transducers (as the two red lines indicate). And this spacing should be exactly according to the value M25 tells you. Note that this method suits for normal Small, Std. M and Large transducer.

**Mounting Transducers in Z-Mount Configuration**

Installation on larger pipes requires careful measurements to the linear and radial placement of the L1 transducers. Failure to properly orient and place the transducers on the pipe may lead to weak signal strength and/or inaccurate readings. The section below details a method for properly locating the transducers on larger pipes. This method requires a roll of paper such as freezer paper or wrapping paper, masking tape and a marking device.

1. Wrap the paper around the pipe in the manner shown in **Figure 2.4**. Align the paper ends to within 0.25 inches [6 mm].

2. Mark the intersection of the two ends of the paper to indicate the circumference.

Remove the template and spread it out on a flat surface. Fold the template in half, bisecting the circumference. See **Figure 2.5**.

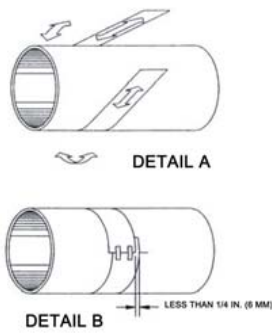

**Figure 2.4**  
Paper Template Alignment

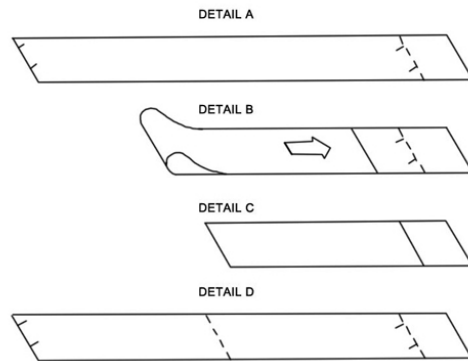

**Figure 2.5**  
Bisecting the pipe circumference

3. Crease the paper at the fold line. Mark the crease. Place a mark on the pipe where one of the transducers will be located. See **Figure 2.1** for acceptable radial orientations. Wrap the template back around the pipe, placing the beginning of the paper and one corner in the location of the mark. Move to the other side of the pipe and mark the pipe at the ends of the crease. Measure from the end of the crease directly across the pipe from the first transducer location) the dimension derived in Step 2, Transducer Spacing. Mark this location on the pipe.

4. The two marks on the pipe are now properly aligned and measured.

If access to the bottom of the pipe prohibits the wrapping of the paper around the circumference, cut a piece of paper to these dimensions and lay it over the top of the pipe.

Length = Pipe O.D. x 1.57; width = Spacing determined on page 2.6

Mark opposite corners of the paper on the pipe. Apply transducers to these two marks.

5. Place a single bead of couplant, approximately 0.05 inch [1.2 mm] thick, on the flat face of the transducer. See **Figure 2.2**. Generally, a silicone-based grease is used as an acoustic couplant, but any grease-like substance that is rated to not “flow” at the temperature that the pipe may operate at, will be acceptable.

- a) Place the upstream transducer in position and secure with a stainless steel strap or other. Straps should be placed in the arched groove on the end of the transducer. A screw is provided
  - b) Try to help hold the transducer onto the strap. Verify that the transducer is true to the pipe - adjust as necessary. Tighten transducer strap securely. Larger pipes may require more than one strap to reach the circumference of the pipe.
6. Place the downstream transducer on the pipe at the calculated transducer spacing. See **Figure 2.6**. Using firm hand pressure, slowly move the transducer both towards and away from the upstream transducer while observing Signal Strength. Clamp the transducer at the position where the highest Signal Strength is observed. Signal Strength of between 60 and 95 percent is acceptable. On certain pipes, a slight twist to the transducer may cause signal strength to rise to acceptable levels.
  7. Secure the transducer with a stainless steel strap or other.

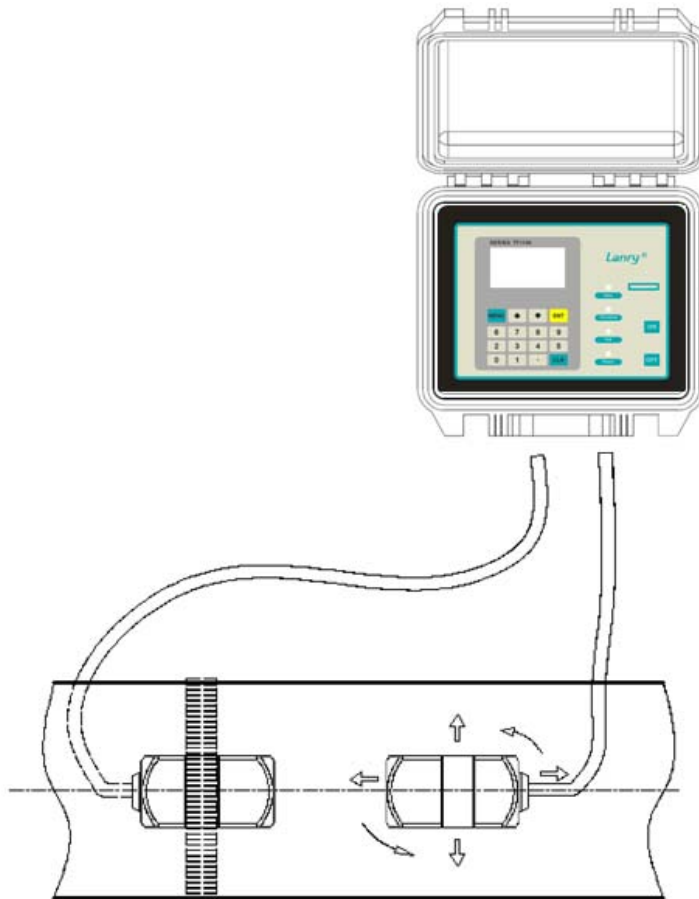

**Figure 2.6 Z-Mode transducer placements**



## 2.5 TRANSDUCER MOUNTING INSPECTION AND COUPLANT APPLICATION

### 2.5.1 Transducer Mounting Inspection

It is very important to use menu operations for TRANSDUCER MOUNTING INSPECTION and Estimation, Refer to 5.16, Use menu windows for Transducer Mounting Inspection.

### 2.5.2 Couplant Application

#### **A, It is also very important for couplant application.**

When mounting the transducers, apply just enough pressure so that the couplant fills the gap between the pipe and transducer. Commonly, the Dow 732 for permanent and Dow 111 for temporary installations, but Dow 111 has a better coupling effect. If Dow 732 was used, ensure that no relative movement between the transducer and the pipe takes place during the setting time and do not apply instrument power for at least 24 hours, Dow 111 also be used for permanent installations(avoid rain or water etc.), setting time is not necessary. We recommend using Dow 111 for permanent installing, and then use Dow732 around the transducer in order to fix the transducer, waterproof cloth is recommended if the Transducers are installed outdoor. Dow 112 for high temperature application.

#### **B, Transducers for High Temperature**

Mounting of high temperature transducers is similar to TF1100 standard transducers; High temperature installations require acoustic couplant Dow Corning 112 that is rated not to flow at the temperature that will be present on the pipe surface.

## PART-3 START OPERATING INSTRUCTIONS

### 3.1 POWER ON

Press the ON key to switch on the instrument and press the OFF to turn off the power.

Once the flow meter is switched on, it will run a self diagnostic program, checking first the hardware and then the software integrity. If there is any abnormality, corresponding error messages will display.

Generally, there should be no display of error messages, and the flow meter will go to the most commonly used Menu Window Number 01 (short for M01) to display the Velocity, Flow Rate, Positive Totalizer, Signal Strength and Signal Quality, meter run status based on the pipe parameters configured last time by the user or by the initial program.

The flow measurement program always operates in the background of the user interface. This means the flow measurement will keep on running regardless of any user menu window browsing or viewing. Only when the user enters new pipe parameters will the flow meter change measurement to the new parameter changes.

When new pipe parameters have been entered or when the power has been just switched on, the flow meter will enter an adjusting mode to make the signals magnified with proper amplification. By this step, the flow meter is going to find the best threshold of receiving signal. The user will see the progress by the number 1, 2, or 3, which are indicated on the right lower corner of the LCD display.

When the transducers have been adjusted on the pipe by the user, the flow meter will re-adjust the signal automatically.

Any user-entered configuration value will be retained into the NVRAM of the flow meter, until it is modified by the user.

### 3.2 Keypad functions

After transducer and connection of appropriate power supply to TF1100, keypad configuration of the instrument can be undertaken. Generally, there should be no display of error messages, and the flow meter will go to the most commonly used Menu Window Number 01 (short for M01) to display the Velocity, Flow Rate, Positive Totalizer, Signal Strength and Signal Quality, based on the pipe parameters entering by the user or by the initial program.

The TF1100 contains a 16-key tactile keypad, allows the user to view and change configuration parameters as shown below.

Follow these guidelines when using TF1100 keypad:

**0**~**9** and **.** to input numbers and decimal.

**CLR** to backspace or delete characters to the left.

The ARROW keys **^** and **v** To return to the last menu or to open the next menu, are used to scroll through menu

configuration parameters; also acts as “+” and “-” functions when entering numbers.

**MENU** To select a menu. Press this key first, input two menu numbers and then enter the selected menu. For instance, to input a pipe Outside diameter, press **MENU** **1** **2** keys, where “12” is the window Address to display the parameter pipe wall thickness.

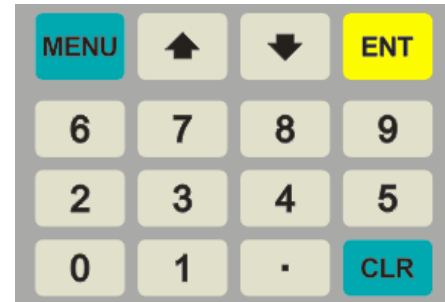

### 3.3 KEYPAD OPERATION

With all of the parameters entered, the instrument setup and measurement displays are subdivided or consolidated into more than 100 independent windows. The user can view the window menu, input parameters, modify settings or display measurement results. These windows are arranged by 2-digit serial numbers (including **^** sign) from 00~99, then to **^** **0**, **^** **8**, etc.. Every window serial number, or so-called window Address code, has a defined meaning. For instance, Window No.11 indicates the parameter input for pipe outside diameter, while Window No.25 indicates the mounting distance between the transducers, etc. (Refer to Part 4 – Windows Display Explanations).

The keypad shortcut to visit a specific window is to press the **MENU** key at any time, then input the 2-digit window Address code. For instance, to input or check the pipe outside diameter, just press the **MENU** , **1** , **1** keys for window Address code 11.

Another method to visit a particular window is to press **^** , **v** and **ENTER** keys to scroll the menu. For instance, if the current window Address code is 66, press **^** key to enter Window No.65, press the **^** again to enter Window No.64; then, press the **v** key to back Window No.65, and press the **v** key again to enter Window No.66.

Example 1. To enter a pipe outside diameter of 218.6, the procedure is as follows:

Press **MENU** **1** **1** keys to enter Window No.11 (the numerical value displayed currently is a previous value). Now press ENTER key. The symbol **>** and the flashing cursor are displayed at the left end of the second line on the Screen. The new value can be

entered by press **2** **1** **8** **.** **6** **ENTER** .

M11  
Outer Diameter  
108 mm

M11  
Outer Diameter  
108 mm  
> 218.6

Example 2. If the pipe material is “Stainless Steel”, press keys **MENU** **1** **4** to enter Window No.14 first. Then press **ENTER** key to modify the options. Now, select the “1. Stainless Steel ” option by pressing **^** and **v** keys, and then press **ENTER** key to confirm the selection. It is possible to press the key **1** to change the selection and wait until “1. Stainless Steel” is displayed on the second line of the screen. Then press the **ENTER** key to confirm.

Generally, press **ENTER** key first if operator wants to enter “modify” condition. If the “modify” is still not possible even after pressing the **ENTER** key, it means that system is locked by a password. To “Unlock” it,

Select “Unlock” in Window No. 47 and enter the original password. The keypad will not respond if the keypad is locked. It only can be unlocked by the entering original password. Select keypad lock functions in Window No. 48. Please consult factory for password if necessary.

### 3.4 TF1100 Window Descriptions

The TF1100 has a unique feature of windows processing for all operations.

These windows are assigned as follows:

00~08 windows for the display of flow rate, velocity, positive total, negative total, net total, heat flow, date & time, meter run status etc.

11~29 windows for initial Parameter Setup: To enter pipe outside diameter, pipe wall thickness, pipe material type, fluid type, transducer type, etc. For TF1100C, pipe material type selection is not necessary.

30~38 windows for flow Units Options: to select the flow unit, totalizer unit, measurement unit, turn totalizers on/off and reset totalizes, etc.

40~49 windows for Setup options: Scale factor, network IDN (Window No.46), system lock (Window No.47) and keypad lock code (Window No.48), etc.

50~89 windows for Input and output setup: relay output setup, 4-20mA outputs, flow batch controller, LCD backlit option, date and time, low/high output frequency, alarm

output, date totalizer, etc.

90~94 windows for Diagnoses: Signal strength and signal quality (Window No.90), **TOM/TOS\*100 (Window No.91)**, flow sound velocity (Window No.92), total time and delta time (Window No.93), Reynolds number and factor (Window No.94), etc.

^0~^8 APPENDIX: Power on/off time, total working hours, on/off times and hardware adjustment, used by the manufacturer only. For further information, please refer to **Part 4 – Windows Display Explanations**. If you have any questions, refer to the step-by-step instructions found in the following section (**3.4.4 Pipe Parameter Entry Shortcuts**).

In fact, users don't need to set up so many steps, just select necessary parameters to set up in the menu.

### 3.5 Pipe Parameter Entry Shortcuts

The following parameters should be entered for normal measurement:

1. Pipe outer diameter
2. Pipe wall thickness
3. Pipe material
4. Liner material parameters (including thickness and sound velocity, if needed)
5. Fluid type
6. Transducer type (The transmitter is available for various transducer types, for TF1100, opt. S, M, L, TF1100-EI is Plug-in type B45 )
7. Transducer mounting methods (refer to **Part 2, W, V, Z**)
- 8. For the TF1100, Clamp-on transducers, the M25 displayed the transducers spacing (two transducers installing distance) should be strictly abode. Also user shall refer to M91 and keep the value of M91 to 97%-103. %.**

In the order stated above, enter the above-mentioned parameters by the following keypad shortcuts:

1. Press    keys to enter Windows No.11, and enter the pipe outside diameter, and then press the ENTER key.
2. Press the  key to enter Window No.12, pipe wall thickness, and press  key.
3. Press the  key to enter Window No.14, press the  key, move the  or  key to select pipe material, and press the ENTER key.
4. Press the  key to enter Window No.16, press the  key, move the  or  key

to select liner material, and press the ENTER key.

5. Press the  $\nabla$  key to enter Window No.20, press the ENTER key, move the  $\wedge$  or  $\nabla$  key to select fluid type, press the ENTER key.

6. Press the  $\nabla$  key to enter Window No. 23, press the ENTER key, move the  $\wedge$  or  $\nabla$  key to select transducer type, and press the ENTER key.

7. Press the  $\nabla$  key to enter Window No.24, press the ENTER key, move the  $\wedge$  or  $\nabla$  key to select transducer-mounting method, and press the ENTER key.

8. Press the  $\nabla$  key to enter Window No.25, accurately install the transducer according to the displayed transducer mounting spacing and the selected mounting method (Refer to Installing the Transducers in Part 2).

9. Press the MENU 0 1 keys to enter Window No.01 to display measurement result.

10. Press the MENU X X keys to directly enter Window No.XX to display Mxx contents, where X is digital number on keypad.

### 3.6 INSTALLATION CHECKUP

Through the checkup of the installation, one can: check the receiving signal strength, the signal quality Q value (M90), the measured traveling time of the signals and the calculated traveling time ratio (M91). Therefore, optimum measurement result and longer running time of the instrument can be achieved.

#### 3.6.1 SIGNAL STRENGTH

Signal strength indicates the amplitude of receiving ultrasonic signals by a 3-digit number. [00.0] means there is no signal detected and [99.9] refers to the maximum signal strength that can be received.

Although the instrument works well if the signal strength ranges from 50.0 to 99.9, stronger signal strength should be pursued, because a stronger signal means a better result. The following methods are recommended to obtain stronger signals:

- Relocate a more favorable location, if the current location is not good enough for a stable and reliable flow reading, or if the signal strength is lower than 70.0.
- Try to polish the outer surface of the pipe, and apply more coupler to increase the signal strength.
- Adjust the transducers both vertically and horizontally while checking the varying signal strength, stop at the highest position, and then check the transducers spacing to make sure the transducers spacing is the same as what the M25 shows.

### 3.6.2 SIGNAL QUALITY

Signal quality is indicated as the Q value in the instrument. A higher Q value would mean a higher Signal and Noise Ratio (short for SNR), and accordingly a higher degree of accuracy would be achieved. Under normal pipe condition, the Q value is in the range 60.0-90.0, the higher the better.

Causation for a lower Q value could be:

- Interference of other instruments and devices such as a powerful transverter working nearby. Try to relocate the flow meter to a new place where the interference can be reduced.
- Bad sonic coupling for the transducers with the pipe. Try to apply more coupler or clean the surface, etc.
- Pipes are difficult to be measured. Relocation is recommended.

### 3.6.3 TOTAL TRANSIT TIME AND DELTA TIME

The numbers displayed on menu window M93 are called total transit time and delta time respectively. They are the primitive data for the instrument to calculate the flow rate inside the pipe. So the flow rate indication will vary accordingly with the total time and delta time.

The total transit time should remain stable or vary a little.

If the delta time fluctuates higher than 20%, it means there are certain kinds of problems with the transducer installation.

### 3.6.4 TIME RATIO BETWEEN THE MEASURED TOTAL TRANSIT TIME AND THE CALCULATED TIME (M91)

This ratio would be used to check the transducer installation. If the pipe parameters are entered correctly and the transducers are installed properly, the value for this ratio should be in the range of  $100\pm 3\%$ . If this range is exceeded, the user should check:

- If the pipe parameters are correctly entered.
- If the actual spacing of the transducers is right and the same as what the window M25 shows.
- If the transducers are installed properly in the right directions.
- If the mounting location is good and if the pipe has changed shape or if there is too much fouling inside the pipes
- Other poor conditions.

## PART-4 WINDOWS DISPLAY EXPLANATIONS

### Windows Display Explanations

Menu Window Numbers	Functions/Display								
M00	Positive, negative, net total flow and run status								
M01	Positive total flow, flow rate , fluid velocity and run status								
M02	Negative total flow, flow rate , fluid velocity and run status								
M03	Net total flow, flow rate , fluid velocity and run status								
M04	Date, time, flow rate, run status								
M05	<p><b>Total heat flow , heat flow rate, fluid velocity and run status</b></p> <table border="1" style="margin-left: auto; margin-right: auto;"> <tr> <td>EFR</td> <td>0.0000kW</td> </tr> <tr> <td>E.T</td> <td>0E0kWh</td> </tr> <tr> <td>Vel</td> <td>0.0000 m/s</td> </tr> <tr> <td>S=00.0, 00.0</td> <td>Q=00</td> </tr> </table>	EFR	0.0000kW	E.T	0E0kWh	Vel	0.0000 m/s	S=00.0, 00.0	Q=00
EFR	0.0000kW								
E.T	0E0kWh								
Vel	0.0000 m/s								
S=00.0, 00.0	Q=00								
M06	Tin/Tout temperature value (4-20mA temperature sensor input for Heat flow measurement)								
M07	Meter run Error Code and run status								
M08	Net total flow today								
<b>Above is display menu(M00-M08)</b>									
<b>M11</b>	Window for entering/changing the outside (outer) diameter of the pipe line. 0 to 4500 mm is the allowed range of the value.								
M12	Window for entering pipe wall thickness								
M13	Window for entering the inside(inner) diameter of the pipe(If user had entered the parameters of M11 and M12, M13 is not necessary to enter, automatically display and can't change)								
M14	<p>Window for selecting pipe material, familiar pipe materials include: (The materials must be equable, compact and can transmit ultrasound)</p> <p>0. Carbon steel    1. Stainless steel    2. Cast iron                      3. Ductile iron    4. Copper                    5. PVC                      6. Aluminum      7. Asbestos    8. Fiberglass                      9. Others</p>								
M16	Window for selecting the liner material, select none for pipes								



	<p>without any liner. familiar liner materials include:</p> <p>0. No liner    1. Tar Epoxy    2. Rubber    3. Mortar    4. Polypropylene    5. Polystryol    6. Polystyrene</p> <p>7. Polyester.    8. Polyethylene    9. Ebonite    10. Teflon</p> <p>11. Others</p>
M18	Window for entering the liner thickness, if there is liner
M20	<p>Window for selecting fluid type</p> <p>familiar liquids types include:</p> <p>0. Water    1. Sea Water    2. Kerosene    3. Gasoline</p> <p>4. Fuel oil    5. Crude Oil    6. Propane at -45°C</p> <p>7. Butane at 0°C    8. Other *    9. Diesel Oil</p> <p>10. Castor Oil    11. Peanut Oil    12. #90 Gasoline</p> <p>13. #93 Gasoline    14. Alcohol    15. Hot water at 125 °C</p>
M21	Window for entering the Fluid Sound Speed, only for “other” liquids. If M20 select “other”, user must enter the fluid sound velocity (inquiry or estimate a suitable value); if you do not select “other” in Menu 20, M21 won’t appear.
M22	Window for entering the viscosity of the “other” liquids, unit of viscosity is cst. If you do not select “other” in Menu 20, M21 won’t appear.
M23	<p>Window for selecting the proper transducer type (XDCR Type), There are different types of transducers for. For TF1100-EC, opt. Standard-S, Standard-M, standard-L, TF1100-EI is Plug-in type B45.</p> <div style="border: 1px solid black; padding: 5px; margin: 10px auto; width: fit-content;"> <p>M23 XDCR Type 0. Standard-M</p> </div> <p>Standard-S: Clamp-on small pipe, 20-40mm</p> <p>Standard-M: Clamp-on standard pipe, 40-1000mm</p> <p>Standard-L: Clamp-on large pipe, 1000mm-4500mm</p> <p>Plug-in B45: Insertion, hot-tapped transducer, 65-4500mm</p>
M24	<p>Window for selecting the transducer mounting method (XDCR Mounting). Four methods can be selected:</p> <p>0. V-method    1. Z-method    2. N-method</p> <p>3. W-method</p>

<p><b>M25</b> <b>*Important</b></p>	<p>Display the transducer mounting spacing. <b>Users need mount transducers exactly according to the spacing distance value M25 displays after users input correct parameter setting.</b></p>
<p><b>M26</b></p>	<p><b>Entry to store the parameter configurations into the internal memory. This is very important step, otherwise, if power off and power on again, the meter may can't memory the parameter configurations.</b></p>
<p>M27</p>	<p>Display liquid cross section area, provide user to validate flow rate or total flow display, commonly it's no matter with user.</p>
<p>M28</p>	<p>Hold poor signal, YES is the default setup. If poor signal appears, meter still have a previous read. Commonly, don't change the default setup.</p>
<p><b>M29</b></p>	<p><b>Empty Pipe Setup</b>, this is very useful for user, Empty pipe line or pipe shaking etc., meter may display error or undesired read, user can setup a Q value less than normal Q value, for example, normal Q value is 60-70, user can enter Empty Pipe Setup value 50, such, meter will display 0 flow rate when Q value is less than 50. In good pipe status, please do not setup this value too small.</p>
<p><b>Above is initial parameter setup (M11-M29)</b></p>	
<p>M30</p>	<p>Window for selecting Measurement Unit system. Default value is 'Metric'. The change from English to Metric or vice versa will not affect the unit for totalizers.</p>
<p>M31</p>	<p>Window for selecting Flow Rate Unit,</p> <div style="border: 1px solid black; padding: 5px; width: fit-content; margin: 10px auto;"> <p>M31 Flow Rate Unit M3/h</p> </div> <p>To change it, press key "ENTER", will display:</p> <div style="border: 1px solid black; padding: 5px; width: fit-content; margin: 10px auto;"> <p>M31 Flow: Units/T &gt; <b>Cubic Meters</b></p> </div> <p>The &gt; is flashing, press scroll key ^ or v to select desired unit, then press "ENTER", to select time unit will display:</p>

	<div style="border: 1px solid black; padding: 5px; width: fit-content; margin-bottom: 10px;"> M31  Cubic Meters  &gt;            /T </div> <p>Flow rate unit can be in</p> <table style="width: 100%; border-collapse: collapse;"> <tr> <td style="width: 60%;">0. Cubic Meters</td> <td style="width: 20%;">short for</td> <td style="width: 20%;">(m3)</td> </tr> <tr> <td>1. Liter</td> <td></td> <td>(l)</td> </tr> <tr> <td>2. American Gallon</td> <td></td> <td>(gal)</td> </tr> <tr> <td>3. Imperial Gallon</td> <td></td> <td>(igl)</td> </tr> <tr> <td>4. Million Gallon (American)</td> <td></td> <td>(mgl)</td> </tr> <tr> <td>5. Cubic Feet</td> <td></td> <td>(cf)</td> </tr> <tr> <td>6. American Liquid Barrel</td> <td></td> <td>(bal)</td> </tr> <tr> <td>7. Imperial Liquid Barrel</td> <td></td> <td>(ib)</td> </tr> <tr> <td>8. Oil Barrel</td> <td></td> <td>(ob)</td> </tr> </table> <p>The flow unit in terms of time can be per day, per hour, per minute or per second. So there are 36 different flow rate units in total for selection.</p>	0. Cubic Meters	short for	(m3)	1. Liter		(l)	2. American Gallon		(gal)	3. Imperial Gallon		(igl)	4. Million Gallon (American)		(mgl)	5. Cubic Feet		(cf)	6. American Liquid Barrel		(bal)	7. Imperial Liquid Barrel		(ib)	8. Oil Barrel		(ob)	<p>The &gt; is flashing, press scroll key ^ or v to select desired time unit, then press "ENTER", then. Will display desired flow rate unit.</p>
0. Cubic Meters	short for	(m3)																											
1. Liter		(l)																											
2. American Gallon		(gal)																											
3. Imperial Gallon		(igl)																											
4. Million Gallon (American)		(mgl)																											
5. Cubic Feet		(cf)																											
6. American Liquid Barrel		(bal)																											
7. Imperial Liquid Barrel		(ib)																											
8. Oil Barrel		(ob)																											
M32	<p>Window for selecting Totalizers Unit, working unit default is cubic meters, if change it, press ENTER, then press scroll key ^ or v, to select desired unit.</p>																												
M33	<p>Select Totalizer Multiplier</p> <p>The multiplier ranges from 0.001 to 10000, default value is ×1, addition, if select total flow pulse output, this value represent one pulse corresponding value.</p>																												
M34	<p>Turn on or turn off the NET Totalizer</p>																												
M35	<p>Turn on or turn off the Positive Totalizer</p>																												
M36	<p>Turn on or turn off the Negative Totalizer</p>																												
M37	<p>Totalizer Reset, the following options are available:</p> <p>No</p> <p>YES</p> <p>Restore the instrument to the default parameters as the manufacturer did (Reset system) by pressing the dot key <span style="border: 1px solid black; padding: 0 2px;">.</span> followed by the ◀ key. Take care or make note on the</p>																												

	parameters before doing restoration
M38	<p>The Manual Totalizer is a separate totalizer, press “ENTER” to start, and press “ENTER” to stop it. It is used for flow measurement, calculation and manual calibration.</p> <p>Press ENTER When Ready.</p>
<b>Above is flow units options(M30-M38)</b>	
M40	<p>Flow rate Damping for displaying a stable read. The input range is 0 to 999 seconds.</p> <p>0 means there is no damping. Default value is 10 seconds; common setup value is 1-10 seconds.</p>
M41	<p>Low Flow Cutoff, may be used in order to force a zero display at lower flows and avoid incorrect totalizer.</p> <p>For instance, this value is 0.02m/s, the meter will display zero when flow rate is less than <math>\pm 0.02\text{m/s}</math>.</p> <div style="border: 1px solid black; padding: 5px; width: fit-content; margin-left: auto; margin-right: auto;"> <p>M41 Low Flow Cutoff 0.02m/s</p> </div>
M42	<p>Set Zero, when the fluid is in the static state, the displayed value is called “zero point”. When the “Zero Point” is not really at zero, the incorrect read value is going to be added into the actual flow values.</p> <p>Set Zero must be carried out after the transducers are right installed and the flow inside is in the absolute static state (no liquid moved in the pipe line). Set Zero also is very important step when recalibrating the meter in lab. Doing this step enhances the measuring accuracy and flow offset can be eliminated.</p>
M43	<p>Reset Zero, clear the zero point set by the user, and restore the zero point set by the manufacturer.</p>
M44	<p>Manual Zero Point. Set up a manual flow offset. Generally this value should be 0.</p>
M45	<p>The Scale Factor is used to modify the measurement results, factory default is 1.0 or other value depend on calibration, please see the calibration data sheet and save this sheet. If really necessary, the user can enter a numerical value other than factory default value according to re-calibration results.</p>

M46	Network environment Identification Number for PC communication system.
M47	System Lock, to avoid modification of the parameters, contact factory for the password.
M48	Keypad Lock Code, enter a password in order to prevent unauthorized keypad operating. Unlock it only using the correct password. If forgot, contact factory for the password to unlock it.
M49	Comm. Test, for communication test.
M50	<p>Data Logger Option,</p> <div style="border: 1px solid black; padding: 5px; width: fit-content; margin-left: auto; margin-right: auto;"> <p>M50 Logger Option ON</p> </div> <p>If select data logger output, please select “ON”, then, press “ENTER”.</p>
M51	<p>Time setup for the data logger Set up Start time and Interval,</p> <div style="border: 1px solid black; padding: 5px; width: fit-content; margin-left: auto; margin-right: auto;"> <p>M51 Logger Time Start 00:00:00 Interval 00:00:00 Go On 00:00:00</p> </div> <p>if “Go On” time is longer than 24 hours, please use dot key <input type="checkbox"/> on Keypad, as below: **.**.**</p> <div style="border: 1px solid black; padding: 5px; width: fit-content; margin-left: auto; margin-right: auto;"> <p>M51 Logger Time Start 12:30:00 Interval 00:05:00 Go On **.**.**</p> </div> <p>Means it is no time limit.</p>
M52	Data logging direction control: Only Select ‘To RS-232’ is selected, all the data produced by the data logger will be transmitted out through the RS-232 interface.
M53	<p><b>CL Calibration</b> 4-20mA output calibration, Press ENTER when ready</p> <div style="border: 1px solid black; padding: 5px; width: fit-content; margin-left: auto; margin-right: auto;"> <p>M53 CL Calibration Pre ENT When Ready</p> </div> <p>Meter window will display:</p>



	<p>Use a Ammeter to verify 4mA output, if not, use key <math>\wedge</math> or <math>\vee</math>, let the output is 4.0mA</p> <p>Use the same way, let the Output is 20.0mA</p> <p>This function mainly used by TF1100manufacturer.</p>	<div style="border: 1px solid black; padding: 5px; margin-bottom: 10px;"> <p>M53 CL Calibration 4mA==&gt;-035_</p> </div> <div style="border: 1px solid black; padding: 5px;"> <p>M53 CL Calibration 20mA==&gt;-100_</p> </div>
M54	<p>CL Mode Select</p> <p>Select Current Loop output mode</p> <p>Use key <math>\wedge</math> or <math>\vee</math>, can select different mode: 4-20MA, 0-4-20MA, 0-20MA, 20-4-20MA etc.</p> <p>It is useful if negative flow occurs.</p> <p>For instance, select 0-4-20MA output; user can define 0-4MA as negative flow, 4-20MA as positive flow.</p>	<div style="border: 1px solid black; padding: 5px;"> <p>M54 CL Mode Select <b>0. 4-20mA</b></p> </div>
M55	<p>CL(Current Loop) 4 MA output Value</p> <p>The flow unit's options are the same as those in Menu 31.</p>	<div style="border: 1px solid black; padding: 5px;"> <p>M55 CL 4mA OutputVal <b>0 m3/h</b></p> </div>
M56	<p>CL(Current Loop) 20MA output Value</p> <p>The flow unit's options are the same As those in Menu 31.</p> <p>Press Enter to change the displayed Value.</p>	<div style="border: 1px solid black; padding: 5px;"> <p>M56 CL 20mA Output <b>2000m3/h</b></p> </div>
M57	<p>CL Checkup</p> <p>Press ENTER When Ready.</p> <p>It is necessary to re-calibrate the CL output according user's actual Output, the method is similar with M53.</p> <p>User can check up 0MA, 4 MA, 8MA, ...20MA etc. output.</p>	<div style="border: 1px solid black; padding: 5px;"> <p>M57 CL Checkup ENTER When Ready</p> </div>
M58	<p>CL Output display</p>	
M60	<p>Setup the date and time of the meter.</p> <p>Press ENTER to change it if necessary.</p>	
<b>Above is service options and CL output applications</b>		
M61	<p>Display Version information and Electronic Serial Number</p>	

	(ESN) that are unique for each series TF1100heat meter.	
M62	RS232C communication setup Commonly, user should select “9600, None” 9600 is baud rate, check bit is “None”.	M62 RS-232C Setup 9600, None
M63	Analog input temperature sensor range value for heat flow application, wiring terminals is Tin+, Tin-. Press ENTER and use key $\wedge$ or $\vee$ to input value corresponding 4mA and 20mA	
M64	Analog input temperature sensor range value for heat flow application, wiring terminals is Tout+, Tout-. Press ENTER and use key $\wedge$ or $\vee$ to input value corresponding 4mA and 20mA	
M65	Setup the frequency range for the frequency output. The biggest range is 0Hz-9999Hz. Default value is 1-1001 Hz.	
M66	Setup the Low Frequency Output Corresponding Value of Flow Rate. This value correspond to the lowest Frequency value entered in M65.	M66 Low FO Flow Rate 0 m3/h
M67	Setup the High Frequency Output Corresponding Value of Flow Rate. This value correspond to the highest Frequency value entered in M65. Please see the *Note for wiring diagram.	M67 High FO Flow Rate 3000 m3/h
M70	LCD Backlit option. User can select “Always On”, Always Off” or “Lighting for” items, if select “Lighting for”, please entered a second value, it indicates how many seconds the backlight will be on.	
M71	LCD contrast control. The LCD will become darker when a small value is entered.	
M72	Working timer. It can be cleared by pressing ENTER key, and then select YES.	
M73	Alarm #1 Low Value Enter Lowest Flow Rate value that will trigger the Relay	

	wiring terminal output Alarm.
M74	Alarm #1 High Value Enter Highest Flow Rate value that will trigger the Relay wiring terminal output Alarm.
M75	Not used
M76	Not used
M77	Buzzer setup. If a proper input source is selected, the buzzer will beep when the trigger event occurs <ol style="list-style-type: none"> <li>0. No Signal</li> <li>1. Poor Signal</li> <li>2. Not Ready --state error</li> <li>3. Reverse Flow</li> <li>4. Analog Output overflow 100%</li> <li>5. Frequency Output overflow 120%</li> <li>6. Alarm #1</li> <li>7. Alarm #2 (not used)</li> <li>8. Batch Control</li> <li>9. Positive Int Pulse</li> <li>10. Negative Int Pulse</li> <li>11. Energy Pulse</li> <li>12. ON/OFF via RS232</li> <li>13. Fluid Changed –fluid sound speed changed</li> <li>14. Key Stroke ON–ring when press key</li> <li>15. Not using–close the buzzer</li> </ol>
M78	OCT output Selection(Pulse output for flow rate)
M79	Relay Output Setup
M80	Flow Batch Control
M81	Setup Flow Batch Control Value
M82	The history logger of net totalizer net totalizer of day net totalizer of month net totalizer of year
M83	Auto. Correction Auto gain the totalizer flow if system power off



M84	Heat Flow Unit: kWh; GJ
M85	Temp. Selection: 0. From T1, T2 input 1. Fixed temperature difference
M86	Specific Heat Selection
M87	Heat Flow Totalizer
M88	Heat Flow Multiplier
M89	Reset Heat Flow Totalizer
M90	<p>Display signal strength, signal quality, IMPORTANT When installing the transducers, Let Q Value at least <math>\geq 60</math></p> <div style="border: 1px solid black; padding: 5px; width: fit-content; margin-left: auto;"> <p>M90 Strengthen + Quality S=00.0, 00.0 Q=00</p> </div>
M91	<p>Displays the Time Ratio between the Measured Total Transit Time and the Calculated time. If the pipe parameters are entered correctly and the transducers are properly installed, the ratio value should be in the range of <math>100\pm 3\%</math>. Otherwise the entered parameters and the transducer installation should be checked.</p> <div style="border: 1px solid black; padding: 5px; width: fit-content; margin-left: auto;"> <p>M91 TOM/TOS*100 0.0000%</p> </div>
M92	<p>Displays the measured fluid sound speed. Normally this value should be approximately equal to the entered value in Menu 21 when M20 the fluid type select “<b>Other</b>”. If this value has an obvious difference with the actual fluid sound speed, pipe parameters entered and the transducer installation should be checked again. If Menu20, the fluid type doesn’t select “<b>Other</b>”, this window is no matter with user.</p>
M-1	<p>Calibrate T1 at 0°C, We have already done the calibration in our laboratory(the same for M-2, M-3, M-4), so customers do not need to calibrate. When the value has been changed or need to recalibrate, customers can calibrate the value yourselves.</p>
M-2	Calibrate T1 at 200°C
M-3	Calibrate T2 at 0°C
M-4	Calibrate T2 at 200°C

**Note:** Some contents in window menu order are not displayed in new software version, it won't influence user to use TF1100, just press  or  to scroll the menu window and view or setup necessary menu contents.

## PART-5 ENERGY FUNCTION

### 5.1 INTRODUCTION

Series TF1100 heat meter owns an in-built module for energy calculation. It can calculate the thermal enthalpy of the liquid of a certain temperature automatically. Accordingly we can calculate the heat flow and totalizer. Temperature signal is input by analog hardware T1, T2 which can only receive 4-20mA and 0-20mA current signal.

All above results can be transferred to host computer through a communication protocol of the portable Heat Meter. In this case, TF1100heat meter works as data monitoring network RTU, greatly decrease the complexity, cost and enhancing the reliability of the hardware of devices.

### 5.2 WIRING CONNECTION

Analog input can be connected to four 4-20mA temperature signal from outside. When calculating energy, T1 connects to inlet sensor and T2 to outlet sensor.

Menu06 displays the corresponding temperature.

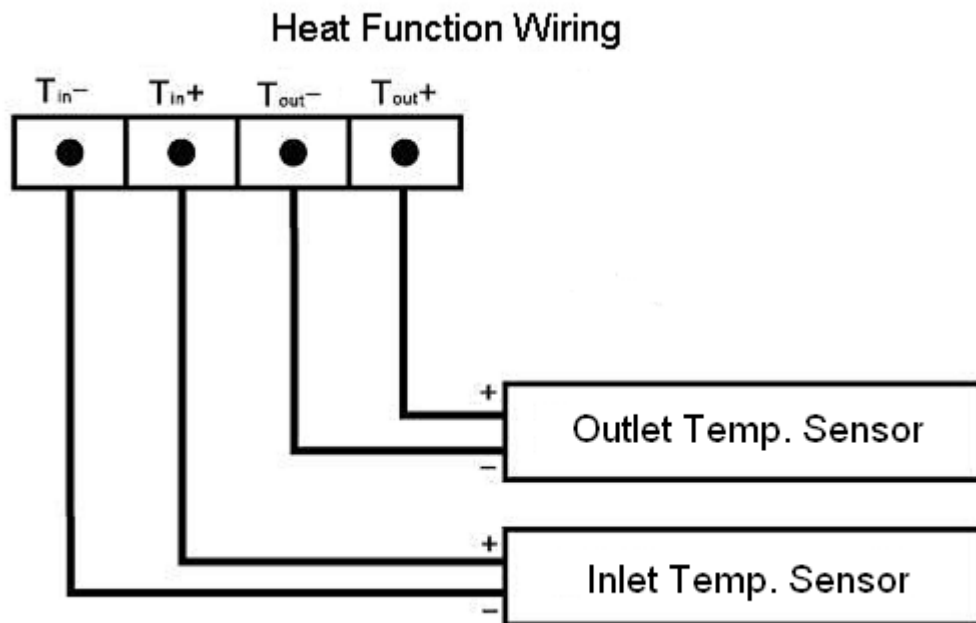

### 5.3 ENERGY CALCULATION

We have two Methods to calculate energy:

Method 1):  $Energy = Flow \times Temp. \text{ Difference} \times \text{heat capacity}$  (Where: Temp. Difference refers to the temperature difference between  $T_{in}$  and  $T_{out}$ ; heat capacity is in Menu 86, commonly it is  $-1.16309KWh/m^3^{\circ}C$ )

Method 2):  $Energy = Flow \times (\text{thermal enthalpy at } T_1 \text{ temp.} - \text{thermal enthalpy at } T_2 \text{ temp.})$

This thermal enthalpy is automatically calculated by heat meter according to international standard.

Menu 84 Energy unit selection, KWh, KC optional.

Menu 85 Temperature Signal Origin Selection

0. From T1, T2 input

1. Fixed temperature difference

Menu 86 Select the specific heat to display according to international standard or fixed value.

Select >0.GB for energy unit KC

**Select >1. Fix Spec. Heat for energy unit KWh**

Menu 87 Open or Close energy flow totalizer.

Menu 88 Totalizer multiplication factor selection

Menu 89 Reset Zero energy totalizer.

If the liquid temperature goes steady, use can remove the temperature sensor and calculate the energy according to the estimated temperature difference.

## 5.4 TEMPERATURE RANGE

Temperature range is defined in Menu63 and Menu64. The first digit in Menu refers to the analog signal value input at 4mA current, the second digit refers to the analog signal value input at 20mA current.

For example, at the condition that when temperature sensor outputs 4mA current, temperature is 0°C, and outputs 20mA current, temperature is 200°C, this temperature sensor is connected to T1, and user needs to input 0, 200 in Menu63. User can check the displayed temperature value in Menu 06.

## PART-6 TEMPERATURE SENSOR INSTALLATION

### 6.1 PT1000 TEMPERATURE SENSOR

TF1100 heat meter utilizes two PT1000 temperature sensors, and the temperature sensors are matching. Temperature sensor cable is provided by manufacturer, and the standard length is 10m.

For measurement accuracy, test security, convenient maintenance, and not affect equipment operation and production operation, we should pay attention to the following before installation:

1. Should be rationally choose installation position, avoid the valve, elbow and equipment installed with thermal resistance.
  2. For measuring the fluid temperature of pipe center, generally the measurement terminal is inserted into the pipe in the center.
  3. Water supply temperature sensor (high temperature point) must be installed in flow transducer downstream side, and is apart from the downstream flow transducer 5DN.
- The return water temperature sensor (low temperature point) should choose the position where is in recent from water supply temperature sensor.

### 6.2 TEMPERATURE SENSOR INSTALATION

#### (a) 6.2.1 CLAMP-ON TEMPERATURE SENSOR

When determining the installation position of temperature sensor, we should pay attention to the pipeline surface. Pipeline surface must be clean before installing temperature sensor, then use belts to fix temperature sensor.

#### (b) 6.2.2 INSERTION TEMPERATURE SENSOR

The insertion temperature sensor is directly contact with measured fluid, so its accuracy is higher. We have two methods to install insertion temperature sensor.

##### 1. Installing by ball valve

For wieldable pipe material, weld ball valve on pipe directly. For non-wieldable pipe material,

first welding a hoop (Usually material is carbon steel) on pipe, then welding ball valve on hoop.

After welding ball valve, drill a suitable hole. Drill into the pipe wall in accordance with the instructions supplied with the drilling machine, at first, please select the slow tap position to drill hole, then select fast tap position.

After drilling a hole, plug in the insertion temperature sensor, adjust the insertion depth, then fix it.

## 2. Installing on pipe directly

Drill a suitable hole on pipe directly, plug in the insertion temperature sensor, adjust the insertion depth, and then fix it.

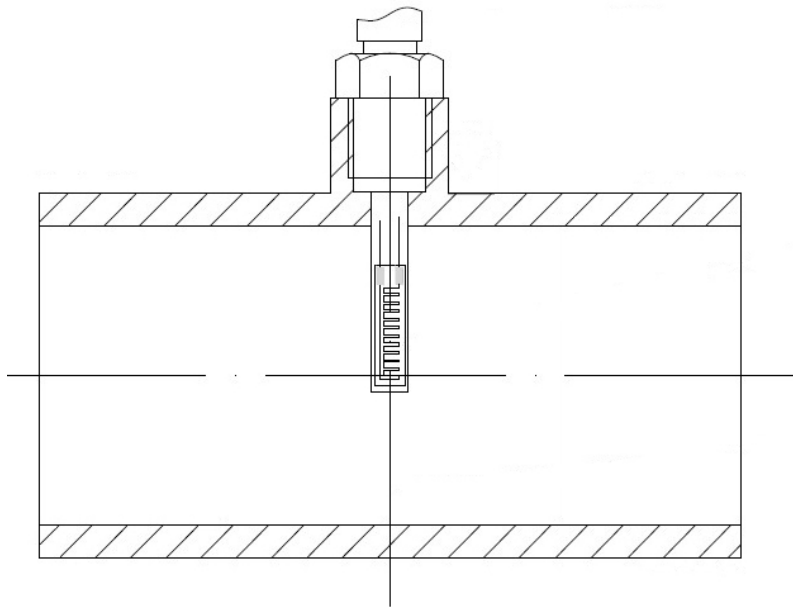

Note: The cables of two temperature sensor must be the same length.

## PART-7 HOW TO USE MENU FUNCTIONS

### 7.1 HOW TO JUDGE WHETHER THE INSTRUMENT WORKS PROPERLY

Generally speaking, when 'R' is displayed in the lowest right corner of LCD display, the instrument is working properly.

If an 'H' flashes on that place, there could be poor signal received. Please refer to the chapters on diagnosis.

If an 'I' is displayed, it means that there is no signal detected.

If a 'J' is displayed, it means that the hardware of this instrument could be out of order. Refer to the chapter on diagnosis.

### 7.2 HOW TO JUDGE THE LIQUID FLOWING DIRECTION

Make sure that the instrument works properly

Check the flow rate for the indication. If the displayed value is positive, the direction of the flow will be from the UP transducer to the Down transducer; if the displayed value is negative, the direction will be from the Down transducer to the UP transducers;

Check the flow rate, if the display value is "+", will it is positive. If the display value is "-", It is negative.

### 7.3 HOW TO RESET THE DEFAULT SETUPS

Use M37, it has another function to recover the default setups. When the 'selection' message is displayed. Press the dot key  first, then press key ◀ then press ENTER, meter will erase all the parameters entered by the user and setup the meter with default values.

### 7.4 HOW TO STABILIZE THE FLOW

The damping acts as a filter for a stable reading. If '0' is entered in window M40, that means there is no damping. A bigger number brings a more stable effect. But bigger damping numbers will prevent the instrument from acting quickly. Numbers 0 to 10 are commonly used for the damping value.

## 7.5 HOW TO USE THE ZERO-CUTOFF FUNCTION

The number displayed in window M41 is called the low-cutoff value. The flow meter will replace these flow rate values that are absolutely less than the low-cutoff value with '0'. This means the flow meter will avoid any invalid accumulation when the actual flow is below the zero-cutoff value.

The low-cutoff value does not affect the flow measurement when the actual flow is absolutely greater than the low-cutoff value.

## 7.6 HOW TO SETUP A ZERO POINT CALIBRATION

It is necessary to establish the true zero flow condition and program that set point into the instrument. If the zero set point is not at true zero flow, a measurement difference may occur. Because every flow meter installation is slightly different and sound waves can travel in slightly different ways through these various installations, a provision is made in this entry to establish "True Zero" flow – SETUP ZERO.

There exists a 'Zero Point' with certain installation which means the flow meter will display a non-zero value when the flow is absolutely stopped. In this case, setting a zero point with the function in window M42 will bring a more accurate measurement result. When do a calibration test, it is also very important.

Make sure that the pipe is full of liquid and the flow is absolutely stopped - securely close any valves and allow time for any settling to occur. Then run the function in window M42 by press the **MENU** **4** **2** keys, then press **ENTER** key and wait until the counter readings displayed in the lower right corner of the screen goes to "00"; thus, the zero set is completed and the instrument indicates the results automatically through Window No.01. Repeat zero set calibration if it still needs to be minimized, i.e. the velocity reading is still high.

## 7.7 HOW TO USE SCALE FACTOR

Scale factor refers to the ratio between "actual value" and "reading value". For instance, when the measurement is 2.00, and it is indicated as 1.98 on the instrument, the scale factor reading is 2/1.98. This means that the best scale factor constant is 1. However, it is difficult to keep the scale factor as "1" on the instrument especially in batch control operations. The difference is called "consistency". High quality products always require high consistency.

The scale factor default is "1" or a factory calibration value (see the calibration data sheet for every meter) for each instrument prior to shipment from the factory. The scale factor

entered must be one that results from actual calibration. Re-calibration or change the Scale factor may be necessary on different pipe lines or different applications in order to obtain better accuracy.

## 7.8 HOW TO USE THE OPERATION LOCKER

The system locker provides a means of preventing inadvertent configuration changes or totalizer resets. Using the menu 48 when the system is locked, menu window browsing can be done without affecting any change, but any modifications are prohibited.

The system can be locked with a one 1 to 8 digit password.

If the password is forgotten, please contact the factory for a common password.

## 7.9 HOW TO USE THE 4~20M A OUTPUT

Refer to Menu 53, 54, 55, 56, 57, 58. Possessing a current loop output exceeding an accuracy of 0.1%, the TF1100 is programmable and configurable with multiple output modules such as 4~20mA or 0~20mA. Select in Window M54. For details, please refer to Part 4 – Windows Display Explanations. In Window M55, enter a 4mA flow value. Enter the 20mA flow value in Window M56. For instance, if the flow range in a specific pipe is 0~1000m<sup>3</sup>/h, enter 0 in Window M55 and 1000 in Window M56. If the flow ranges from -1000~0~2000m<sup>3</sup>/h, configure the 20~4~20mA module by selecting Window M54 when flow direction is not an issue. Enter -1000 in Window M55 and 2000 in Window M56. When flow direction is an issue, module 0~4~20mA is available. When the flow direction displays as negative, the current output is in range of 0~4mA, whereas the 4~20mA is for the positive direction. The output module options are displayed in Window M54. Enter “-1000” in Window M55 and 2000 in Window M56. Calibrating and testing the current loop is performed in Window M57. Complete the steps as follows: Press Menu, 5, 7, ENTER, move ^ or v to display “0mA”, “4mA”, “8mA”, “16mA”, “20mA” readings, connect an ammeter to test the current loop output and calculate the difference. Calibrate it if the difference is within tolerance. Check the present current loop output in Window M58 as it changes along with change in flow.

4-20mA output connect cable, Red is +, black is -.

## 7.10 HOW TO USE THE FLOW RATE FREQUENCY OUTPUT?

Only For Flow Rate Output.

TF1100-EP also can provide a frequency output transmitter function. The find accessory OCT output connect cable, white is +, black is GND, refer to below wiring diagram Figure 5.1, A, B is DC power supply based on pulse receiver voltage, 5-24V is allowable. C,D is pulse input for receiver. Select a resistor that is a maximum of 10% of the input impedance of the receiving device, but do not exceed 10k ohms.



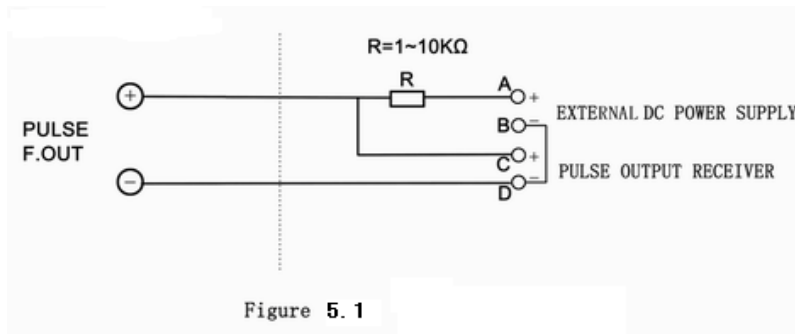

High or low frequency output displayed indicates the high or low flow rate reading. The user can reset the frequency output as well as flow rate per his requirements. For instance: if a pipe flow range is 0~2000m<sup>3</sup>/h, the relative frequency output required is 10~1000Hz, and the configuration is as follows:

In Window M66 (low limit frequency output flow value), input 0;

In Window M67 (high limit frequency output flow value), input 2000;

In Window M65 (Select frequency range), Press ENTER, input Low FO frequency 10, Press  $\checkmark$ , input 1000.

There is no output circuit specially assigned to frequency output. It need to be powered through OCT, and select item FO in Window M78 (item “FO”—Frequency output.).

## 7.11 HOW TO USE RELAY OUTPUT

Relay output **only for Totalizer Output or Relay Alarm Output.**

Once the transmitter is powered on, the “OCT +, -” output is normally Open state.

When the relay is used for totalizer output, connect terminal “OCT + -“, select the corresponding totalizer in Menu 79, and setup the minimum display totalizer increments in Menu 33. Every time the totalizer increases a value set in M33, the relay closed one time.

When the relay is used for alarm output, connect terminal “OCT + -“, select the corresponding item in Menu 79, it can be used for several alarm condition. For example, select “Alarm #1”, set “Alarm #1 Low Value” in Menu 73, and set “Alarm #1 High Value” in Menu 74. When the flow is between the low value and high value, the relay is open state, and when the flow is lower than “Low Value”, or higher than “High Value”, the relay is closed state.

## 7.12 HOW TO SET THE DATE AND TIMER

Use the window M60, press ENTER key and then input the new data and the new time. Press the ENTER key to confirm.

## 7.13 ON/OFF NET TOTALIZER

Window M34 is available to turn net totalizer on and off net. Window No.35 is available to turn the positive totalizer on and off, while Window No.36 is for the negative totalizer. Select “On” to activate the totalizer and “Off” to de-activate the totalizer.

## 7.14 UNITS OPTIONS

Measurement units options, Metric or English, select M30, Press ENTER, and scroll the  $\wedge$  or  $\vee$  to select units; Flow rate units, Select M31, Press ENTER, and scroll the  $\wedge$  or  $\vee$  to select units. Details please refer to Part 4, Windows Display Explanations.

## 7.15 LCD BACKLIT OPT IONS

Adjustment the backlighting in window M70, press MENU, 7 , 0 , then press ENTER, then use  $\wedge$  or  $\vee$  to scroll the menu, to select backlit options.

## 7.16 USE MENU WINDOWS FOR TRANSDUCER MOUNTING INSPECTION

### 7.16.1 Signal Strength

Signal strength (displayed in Window M90) indicates a detected strength of the signal both from upstream and downstream directions. The relevant signal strength is indicated by numbers from 00.0~99.9 in the TF1100. 00.0 represents no signal detected while 99.9 represent maximum signal strength.

Normally, the stronger the signal strength detected, the instrument will work more reliably, as well as the more stable the measurement value obtained.

Adjust the transducer to the best position and check to ensure that enough sonic coupling compounds is applied adequately during installation in order to obtain the maximum signal strength. System normally requires signal strength over 60.0, which is detected from both upstream and downstream directions. If the signal strength detected is too low, the transducer installation position and the transducer mounting spacing should be re-adjusted and the pipe should be re-inspected. If necessary, change the mounting to the Z method.

### 7.16.2 Signal Quality (Q value)

Q value is short for Signal Quality (displayed in Window M90). It indicates the level of the signal detected. In the TF1100, Q value is indicated by numbers from 00~99. 00 represents the minimum signal detected while 99 represent the maximum. Normally, the transducer position should be adjusted repeatedly and coupling compound application should be checked frequently until the signal quality detected is as strong as possible.

### 7.16.3 Total Time and Delta Time

“Total Time and Delta Time”, which displays in Window No.93, indicates the condition of the installation. The measurement calculations in the flow meter are based upon these two

parameters. Therefore, when “Delta Time” fluctuates widely, the flow and velocities fluctuate accordingly. This means that the signal quality detected is too poor. It may be the result of poor pipe-installation conditions, inadequate transducer installation or incorrect parameter input. Generally, “Delta Time” fluctuation should be less than  $\pm 20\%$ . Only when the pipe diameter is too small or velocity is too low can the fluctuation be wider.

#### **7.16.4 Transit Time Ratio (M91)**

Transit Time Ratio indicates if the transducer mounting spacing is accurate. The normal transit time ratio should be  $100\pm 3\%$  if the installation is proper. Check it in Window M91. If the transit time ratio is over  $100\pm 3\%$ , it is necessary to check (1) if the parameters (pipe outside diameter, wall thickness, pipe material, liner, etc.) have been entered correctly, (2) if the transducer mounting spacing

is accordance with the display in Window M25, (3) if the transducer is mounted at the pipe’s centerline on the same diameter, or (4) if the scale is too thick or the pipe mounting is distorted in shape, etc.

#### **7.16.5 Warnings**

1. Pipe parameters entered must be RIGHT; otherwise the flow meter will not work properly.
2. During the installation, apply enough coupling compounds in order to stick the transducer onto the pipe wall. While checking the signal strength and Q value, move the transducer slowly around the mounting site until the strongest signal and maximum Q value can be obtained. Make sure that the larger the pipe diameter, the more the transducer should be moved. Check to be sure the mounting spacing is accordance with the display in Window M25 and the transducer is mounted at the pipe’s centerline on the same diameter. Pay special attention to those pipes that formed by steel rolls (pipe with seams), since such pipe is always irregular. If the signal strength is always displayed as 0.00, that means there is no signal detected. Thus, it is necessary to check that the parameters (including all the pipe parameters) have been entered accurately. Check to be sure the transducer mounting method has been selected properly, the pipe is not worn-out, and the liner is not too thick. Make sure there is indeed fluid in the pipe or the transducer is not very close to a valve or elbow, and there are not too many air bubbles in the fluid, etc. With the exception of these reasons, if there is still no signal detected, the measurement site has to be changed.
3. Make sure that the flow meter is able to run properly with high reliability. The stronger the signal strength displayed, the higher the Q value reached. The longer the flow meter runs accurately, the higher the reliability of the flow rates displayed. If there is interference from ambient electromagnetic waves or the signal detected is too poor, the flow value displayed is not reliable; consequently, the capability for reliable operation is reduced.
4. After the installation is complete, power on the instrument and check the result accordingly.

## PART-8 TROUBLESHOOTING AND FAQ

### 8.1 TROUBLESHOOTING

The TF1100 ultrasonic flow meter has advanced self-diagnostics functions and displays any errors in the upper right corner of the LCD via definite codes in a date/time order. Hardware error diagnostics are usually performed upon each power on. Some errors can be detected during normal operation. Undetectable errors caused by incorrect settings and unsuitable measurement conditions can be displayed accordingly. This function helps to detect the errors and determine causes quickly; thus, problems can be solved in a timely manner according to the solutions listed in the following tables.

Errors displayed in the TF1100 are divided into two categories: Table 1 is for errors displayed during self-diagnostics upon power on. “\* F” may be displayed on the upper left corner of the screen after entering the measuring mode. When this occurs, it is necessary to power on for self-diagnostics once again to detect and solve possible errors using the table below. If a problem still exists, please contact the factory or the factory’s local representative for assistance.

Table 2 applies when errors caused by incorrect settings and signals are detected and are announced by error codes displayed in Window M07.

**Table 1. Self-diagnoses and error solutions (upon power on)**

LCD Display	Cause	Solution
Rom Parity Error	* System ROM illegal or error	* Contact the factory
Stored Data Error	* System stored data block error	* Power on again or contact the factory
SCPU Fatal Error!	* SCPU circuit fatal error	* Power on again or contact the factory
Timer Slow Error Timer Fast Error	* System clock error	* Contact the factory
CPU or IRQ Error	* CPU or IRQ problem	* Power on again
System RAM Error	* System RAM questionable	* Power on again or contact the factory
Time or Bat Error	* System date time chip error	* Power on again or contact the factory
No Display, Erratic or Abnormal Operation	* Bad wiring connection	* Check wiring connections
Stroke Key -No Response	*Keypad locked or bad plug connection	* Enter the unlock password if the keypad is locked

**Table 2. Error codes and solutions (during operation)**

Code	M08 Display	Cause	Solution
*R	System Normal	* System normal	No errors
*J	SCPU Fatal Error	* Hardware defect	* Contact the factory
*I	Signal Not Detected	*Signal not detected. *Spacing is not correct between the transducers or not enough coupling compound applied to face of transducers. * Transducers installed improperly. * Scale is too thick. * New pipe liner.	* Attach transducer to the pipe and tighten it securely. Apply a plenty of coupling compound on transducer and pipe wall. * Remove any rust, scale, or loose paint from the pipe surface. Clean it with a file. * Check the initial parameter settings. * Remove the scale or change the scaled pipe section. Normally, it is possible to change a measurement location. The instrument may run properly at a new site with less scale. * Wait until liners solidified and saturated.
*H	Low Signal Strength	* Low signal strength. * Cause refers to above-mentioned reasons.	* Solution refers to above-mentioned solutions.
*H	Poor Signal Quality	* Poor signal quality * All reasons are included in the above-mentioned causes.	* Solution refers to above-mentioned solutions.
*E	Current Loop over 20mA (No influence normally. Ignore it if no current output is being used.)	* 4-20mA current loop over 120%. * Improper settings to current loop output.	* Check settings (refer to Window M56) and confirm if actual flow is too high.

*Q	Frequency output over set value No influence normally. Ignore it if no frequency output is being used.	* Frequency output over 120%. * Improper settings to frequency output or actual flow are too high.	* Check settings (refer to Window M66-M69) and confirm if the actual flow is too high.
*F	Refer to Table 1.	* Error in self-diagnoses during power on. * Permanent hardware error.	* Power on again; resolve it by the method listed in Table 1. If it is still a problem, contact the factory. * Contact the factory.

## 8.2 FREQUENTLY ASKED QUESTIONS AND ANSWERS

**Q:** New pipe, high quality material, and all installation requirements met: why still no signal detected?

**A:** Check pipe parameter settings, installation method and wiring connections. Confirm if the coupling compound is applied adequately, the pipe is full of liquid, transducer spacing agrees with the screen readings and the transducers are installed in the right direction.

**Q:** Old pipe with heavy scale inside, no signal or poor signal detected: how can it be resolved?

**A:** Check if the pipe is full of fluid. Try the Z method for transducer installation (If the pipe is too close to a wall, or it is necessary to install the transducers on a vertical or inclined pipe with flow upwards instead of on a horizontal pipe). Carefully select a good pipe section and fully clean it, apply a wide band of coupling compound on each transducer surface (bottom) and install the transducer properly. Slowly and slightly move each transducer with respect to each other around the installation point until the maximum signal is detected. Be careful that the new installation location is free of scale inside the pipe and that the pipe is concentric (not distorted) so that the sound waves do not bounce outside of the proposed area. For pipe with thick scale inside or outside, try to clean the scale off, if it is accessible from the inside. (Note: Sometimes this method might not work and sound wave transmission is not possible because of the a layer of scale between the transducers and pipe inside wall) .

**Q:** Why is the CL output abnormal?

**A:** Check to see if the desired current output mode is set in Window M54. Check to see if the maximum and minimum current values are set properly in Windows M55 and M56. Re-calibrate CL and verify it in Window M53.

**Q:** Why is the flow rate still displayed as zero while there is fluid obviously inside the pipe and a symbol of “R” displayed on the screen?

**A:** Check to see if “Set Zero” was carried out with fluid flowing inside the pipe (Refer to

Window M42) . If it is confirmed, recover the factory default in Window M43.

**Q:** With a poor measurement site environment in the plant and the voltage and power supplies fluctuating widely, is the instrument really able to keep running 24 hours a day repeatedly without stopping and last for several years under such conditions?

**A:** TF1100 is designed to work with high reliability under such conditions. It is provided with an intelligent signal conditioning circuit and internal correction circuitry. It will work under strong interference conditions and is able to adjust itself with strong or weak sound waves. It will work in a wide band of voltage: 90-260VAC or 8V~28V DC voltage.

**Q:** Why is the pipe not full of liquid or no flow in pipe, but still displays an unstable or wrong reading?

**A:** Pipe must be full of liquid, if not, ENTER the menu window M29, setup a EMPTY PIPE Q VALUE less than normal Q value (pipe is full of liquid), cut off abnormal reading, TF1100 will display Zero reading.

## PART-9 WARRANTY AND SERVICE

### 9.1 WARRANTY

The manufacturer provides one year warranty on all products, free of charge, but the users should be responsible for the one-way transportation fee from the customer to the factory.

### 9.2 SERVICE

The manufacturer provides instrument installation for our customers, and the charges will be made according the cost.

- (1) For any hardware failure of the instrument, we recommend that our customers send back the instrument to our factory for service, due to the fact that the instrument is made of microprocessors and it will be difficult to perform field maintenance. Before sending back the instrument, please try to contact the factory first to make sure what the problem is.
- (2) For other operational problems, please contact our local distributor by telephone, fax or email. In most cases, the problem could be solved immediately.



## APPENDIX 1 TRANSDUCER GUIDE RAIL INSTALLATION

### Introduction

The guide rail is designed for clamp-on transducer installation, it make the installation simple, allocation precise, fixation stable, and it also can meet to multiple transducer mounting methods.

### Preparation

1. Before you attach the transducers you should first ensure that the proposed location satisfies the distance requirements as **Table 2.1**, otherwise the resulting accuracy of the flow readings may be affected.
2. Prepare the pipe by degreasing it and removing any loose material or flaking paint in order to obtain the best possible surface. A smooth contact between pipe surface and the face of the transducers is an important factor in achieving a good ultrasound signal strength and therefore maximum accuracy.
3. Parts prepare



← Chins (2pcs)



Transducer rails →



← Spring (2pcs)

## Installation steps

### 1. Installation Steps for V and W Transducer Mounting Method

When using V or W method to install transducers, install the two transducers on the same side of pipeline.



#### Steps:

1. Connect the chains and spring.
2. Lay on enough couplant on the transducer.
3. Connect the transducers cable.
4. Enter the application parameters in transmitter to get the XDCR spacing in menu 25.
5. Install and fix the transducers on the ruler using knurled screws.( note if the wrong space is applied, the measurement fails or the measurement will have wrong values)
6. Fix the transducers using the chains and springs.
7. Approach the transducers to the pipe by adjusting the knurled screw until the transducer is pressed slightly onto the pipe.

### 2 Installation Steps for Z and N Transducer Mounting Method

When using Z or N method to install transducers, install the two transducers respectively on the opposite sides of pipeline. Installation steps are same as for W and V transducer mounting method without ruler.

When finishing the installation, it will show as follow:

**Notes:**

1. Equally spread couplant on measuring side of transducer, and then put transducer into bracket from broadside, make sure pipeline and transducer have good coupling.
2. Do not over tighten to prevent couplant extrusion.
3. Ensure that the two brackets are on the same axial surface.

## APPENDIX 3 FLUID CHARACTERISTIC (SOUND SPEED)

### 1. FLUID PROPERTIES

Fluid	Specific Gravity	Sound Speed		delta-v/degree C	Kinematic Viscosity	Absolute viscosity
	20 degrees C	m/s	ft/s	m/s/degree C	Centistokes	Centipoise
Acetate, Butyl		1270	4163.9			
Acetate, Ethyl	0.901	1085	3559.7	4.4	0.489	0.441
Acetate, Methyl	0.934	1211	3973.1		0.407	0.380
Acetate, Propyl		1280	4196.7			
Acetone	0.79	1174	3851.7	4.5	0.399	0.316
Alcohol	0.79	1207	3960.0	4.0	1.396	1.101
Alcohol, Butyl	0.83	1270	4163.9	3.3	3.239	2.688
Alcohol, Ethyl	0.83	1180	3868.9	4	1.396	1.159
Alcohol, Methyl	0.791	1120	3672.1	2.92	0.695	0.550
Alcohol, Propyl		1170	3836.1			
Alcohol, Propyl	0.78	1222	4009.2		2.549	1.988
Ammonia	0.77	1729	5672.6	6.7	0.292	0.225
Aniline	1.02	1639	5377.3	4.0	3.630	3.710
Benzene	0.88	1306	4284.8	4.7	0.711	0.625
Benzol, Ethyl	0.867	1338	4389.8		0.797	0.691
Bromine	2.93	889	2916.7	3.0	0.323	0.946
n-Butane	0.60	1085	3559.7	5.8		
Butyrate, Ethyl		1170	3836.1			
Carbon dioxide	1.10	839	2752.6	7.7	0.137	0.151
Carbon tetrachloride	1.60	926	3038.1	2.5	0.607	0.968
Chloro-benzene	1.11	1273	4176.5	3.6	0.722	0.799
Chloroform	1.49	979	3211.9	3.4	0.550	0.819
Diethyl ether	0.71	985	3231.6	4.9	0.311	0.222
Diethyl Ketone		1310	4295.1			
Diethylene glycol	1.12	1586	5203.4	2.4		
Ethanol	0.79	1207	3960.0	4.0	1.390	1.097
Ethyl alcohol	0.79	1207	3960.0	4.0	1.396	1.101
Ether	0.71	985	3231.6	4.9	0.311	0.222
Ethyl ether	0.71	985	3231.6	4.9	0.311	0.222
Ethylene glycol	1.11	1658	5439.6	2.1	17.208	19.153
Freon R12		774.2	2540			
Gasoline	0.7	1250	4098.4			
Glycerin	1.26	1904	6246.7	2.2	757.100	953.946
Glycol	1.11	1658	5439.6	2.1		
Isobutanol	0.81	1212	3976.4			
Iso-Butane		1219.8	4002			
Isopentane	0.62	980	3215.2	4.8	0.340	0.211
Isopropanol	0.79	1170	3838.6		2.718	2.134
Isopropyl alcohol	0.79	1170	3838.6		2.718	2.134
Kerosene	0.81	1324	4343.8	3.6		

Linalool		1400	4590.2			
Linseed Oil	.925-.939	1770	5803.3			
Methanol	0.79	1076	3530.2	2.92	0.695	0.550
Methyl alcohol	0.79	1076	3530.2	2.92	0.695	0.550
Methylene chloride	1.33	1070	3510.5	3.94	0.310	0.411
Methylethyl Ketone		1210	3967.2			
Motor Oil (SAE 20/30)	.88-.935	1487	4875.4			
Octane	0.70	1172	3845.1	4.14	0.730	0.513

Oil, Castor	0.97	1477	4845.8	3.6	0.670	0.649
Oil, Diesel	0.80	1250	4101			
Oil (Lubricating X200)		1530	5019.9			
Oil (Olive)	0.91	1431	4694.9	2.75	100.000	91.200
Oil (Peanut)	0.94	1458	4783.5			
Paraffin Oil		1420	4655.7			
Pentane	0.626	1020	3346.5		0.363	0.227
Petroleum	0.876	1290	4229.5			
1-Propanol	0.78	1222	4009.2			
Refrigerant 11	1.49	828.3	2717.5	3.56		
Refrigerant 12	1.52	774.1	2539.7	4.24		
Refrigerant 14	1.75	875.24	2871.5	6.61		
Refrigerant 21	1.43	891	2923.2	3.97		
Refrigerant 22	1.49	893.9	2932.7	4.79		
Refrigerant 113	1.56	783.7	2571.2	3.44		
Refrigerant 114	1.46	665.3	2182.7	3.73		
Refrigerant 115		656.4	2153.5	4.42		
Refrigerant C318	1.62	574	1883.2	3.88		
Silicone (30 cp)	0.99	990	3248		30.000	29.790
Toluene	0.87	1328	4357	4.27	0.644	0.558
Transformer Oil		1390	4557.4			
Trichlorethylene		1050	3442.6			
1,1,1-Trichloro- thane	1.33	985	3231.6		0.902	1.200
Turpentine	0.88	1255	4117.5		1.400	1.232
Water, distilled	0.996	1498	4914.7	-2.4	1.000	0.996
Water, heavy	1	1400	4593			
Water, sea	1.025	1531	5023	-2.4	1.000	1.025
Wood Alcohol	0.791	1076	3530.2	2.92	0.695	0.550
m-Xylene	0.868	1343	4406.2		0.749	0.650
o-Xylene	0.897	1331.5	4368.4	4.1	0.903	0.810
p-Xylene		1334	4376.8		0.662	

## 2. WATER SOUND SPEED

**Water Sound Speed table ( pressure: 1 bar)**

Units: Sound Speed: m/s

Temperature °C	Sound Speed	Temperature °C	Sound Speed	Temperature °C	Sound Speed	Temperature °C	Sound Speed
0	1402.3	25	1496.6	50	1542.5	75	1555.1
1	1407.3	26	1499.2	51	1543.5	76	1555.0
2	1412.2	27	1501.8	52	1544.6	77	1554.9
3	1416.9	28	1504.3	53	1545.5	78	1554.8
4	1421.6	29	1506.7	54	1546.4	79	1554.6
5	1426.1	30	1509.0	55	1547.3	80	1554.4
6	1430.5	31	1511.3	56	1548.1	81	1554.2
7	1434.8	32	1513.5	57	1548.9	82	1553.9
8	1439.1	33	1515.7	58	1549.6	83	1553.6
9	1443.2	34	1517.7	59	1550.3	84	1553.2
10	1447.2	35	1519.7	60	1550.9	85	1552.8
11	1451.1	36	1521.7	61	1551.5	86	1552.4
12	1454.9	37	1523.5	62	1552.0	87	1552.0
13	1458.7	38	1525.3	63	1552.5	88	1551.5
14	1462.3	39	1527.1	64	1553.0	89	1551.0
15	1465.8	40	1528.8	65	1553.4	90	1550.4
16	1469.3	41	1530.4	66	1553.7	91	1549.8
17	1472.7	42	1532.0	67	1554.0	92	1549.2
18	1476.0	43	1533.5	68	1554.3	93	1548.5
19	1479.1	44	1534.9	69	1554.5	94	1547.5
20	1482.3	45	1536.3	70	1554.7	95	1547.1
21	1485.3	46	1537.7	71	1554.9	96	1546.3
22	1488.2	47	1538.9	72	1555.0	97	1545.6
23	1491.1	48	1540.2	73	1555.0	98	1544.7
24	1493.9	49	1541.3	74	1555.1	99	1543.9

### 3. PIPE MATERIAL SOUND SPEED TABLE

Pipe Material Sound Speed Table	Sound Speed(m/s)	Liner Material	Sound Speed (m/s)
Steel	3206	Teflon	1225
ABS	2286	Titanium	3150
Aluminum	3048	Cement	4190
Brass	2270	Tar Epoxy	2540
Cast Iron	2460	Porcelain Enamel	2540
Bronze	2270	Glass	5970
Fiber Glass	3430	Plastic	2280
Glass	3276	Polyethylene	1600
Polyethylene	1950	PTFE	1450
PVC	2540	Rubber	1600

## APPENDIX 4 TF1100 COMMUNICATIONS PROTOCOL

(For TF1100-EC/EI)

### 1. OVERVIEW

The TF1100 has communication protocol. Its hardware directly supports a modem, a composition of flow data monitoring system that is economical, reliable and based on telephone line transmission. It can also be connected to a RS-485 or RS232C connectors based on jumpers on circuit board for user's option.

Two basic schemes can be chosen for networking, i.e. the analog current output method only using the TF1100 or the RS232 communication method via serial port directly using the TF1100. The former is suitable to replace dated instruments in old monitoring networks. The later is used in new monitoring network systems. It has advantages such as low hardware investment and reliable system operation.

When the serial port communication method is directly used to implement a monitoring network system, the address identification code (in window M46) of the flowmeter is used as network address code. Expanded command set with [W] is used as communication protocol. Thus analog current loop and OCT output of TF1100 can be used to control the opening of a control valve. The relay output can be used to power-on/off other equipment. The analog input of the system can be used to input signals such as temperature. The system provides an RTU function for flow measurement.

RS-232C (0~15m) or RS-485(0~1000m) can be directly used for data transmission link for a short distance. Current loop, radio transmission and modem can be used in medium or long distance transmission.

When the TF1100 is used in a network environment, various operations can be performed at the host device, except for programming of the address identification code, which needs to be done at the TF1100 keyboard.

The command answer mode is used in data transmission, i.e. the host device issues commands and the flowmeter answers correspondingly.

Common/special flow/thermal data monitoring system developed by our company can be used for flow data collection. Based on characteristics of the TF1100 flowmeter, the system makes full use of software and hardware designs with flowmeter features. The systems are simple, clear, low cost, and reliable in operation.

### 2. SERIAL PORT DEFINITIONS

Now TF1100 communication output is RS485 or RS232C based on user's selection.

RS232C connector is a 9 pins connector:

Pin 1, pin 4, pin 6, pin 7, pin 9: empty

Pin2: RXD receive

Pin3: TXD send

Pin5: Ground

Pin 8: +5V

### 3. RS232 COMMUNICATION PROTOCOL AND THE USE

The communication protocol format used by the TF1100 ultrasonic flowmeter is: The host device requests the flowmeter to answer by sending a "command". The baud rate of



asynchronous communication (Primary station: computer system; Secondary station: ultrasonic flowmeter) is generally 9600bit/s. A single byte data format (10 bits): one start bit, one stop bit and 8 data bits. Check bit: none.

### 3.1 Protocol Select

TF1100 series flowmeter can't support protocol 0 and protocol 1 at the same time, in Menu +6, select protocol 0 or protocol 1.

**When use RS232 for communication, select protocol 0 in menu +6.**

### 3.2 Basic commands

A data character string is used to express basic commands and a carriage return character is used to express the end of the command. The characteristic is that the length of data is flexible. Frequently used commands are as follows:

Table A-1 Communication commands

Command	Function	DATA format
DQD(cr) <b>Note:0</b>	Return Flow rate per day	±d.dddddddE±dd(cr) <b>note:1</b>
DQH(cr)	Return Flow rate per hour	±d.dddddddE±dd(cr)
DQM(cr)	Return Flow rate per minute	±d.dddddddE±dd(cr)
DQS(cr)	Return Flow rate per second	±d.dddddddE±dd(cr)
DV(cr)	Return Flow velocity	±d.dddddddE±dd(cr)
DI+(cr)	Return Positive totalizer	±dddddddE±d(cr) <b>Note:2</b>
DI-(cr)	Return Negative totalizer	±dddddddE±d(cr)
DIN(cr)	Return Net totalizer	±dddddddE±d(cr)
DIE(cr)	Return Positive Heat totalizer	±dddddddE±d(cr)
DID(cr)	Return Identification Number	dddd(cr) 5 bits in length
E(cr)	Return heat flow rate per second	±d.dddddddE±dd(cr)
DL(cr)	Return Signal Strength and quality	UP:dd.d,DN:dd.d,Q=dd(cr)
DS(cr)	Return percentage of Analog Output	±d.dddddddE±dd(cr)
DC(cr)	Return current error code	<b>Note: 3</b>
DA(cr)	Alarm signal of OCT or RELAY	TR:s,RL:s(cr) <b>Note: 4</b>
DT(cr)	Return current date and time	yy-mm-dd,hh:mm:ss(cr)

M@(cr)	Send a key value as if a key is pressed on TF1100 panel	M@(cr) <b>Note:5</b>
LCD(cr)	Return currently displayed content on the current LCD display	
C1(cr)	OCT actuated	
C0(cr)	OCT not actuated	
R1(cr)	RELAY actuated	
R0(cr)	RELAY not actuated	
FOddd(cr)	Let the FO output with a frequency in “ddd” value	Dodd(cr)(lf)
Aoa(cr)	Let the Analog Output with a value” a”	AOa(cr)(lf) <b>Note:6</b>
BA1(cr)	Return AI1 value (0~20mA)	±d.dddE±dd(cr)(lf)
BA2(cr)	Return AI2 value (0~20mA)	±d.dddE±dd(cr)(lf)
BA3(cr)	No used	±d.dddE±dd(cr)(lf)
BA4(cr)	No used	±d.dddE±dd(cr)(lf)
AI1(cr)	Return AI1 input value	±d.dddE±dd(cr)(lf)
AI2(cr)	Return AI2 input value	±d.dddE±dd(cr)(lf)
AI3(cr)	No used	±d.dddE±dd(cr)(lf)
AI4(cr)	No used	±d.dddE±dd(cr)(lf)
ESN(cr)	Return TF1100 Electronic Serial Number(ESN)	dddddt(cr)(lf) <b>Note:7</b>
N	Networking command Prefix of a single byte address	<b>Note:8</b>
W	Networking command Prefix of numeric string address	<b>Note:8</b>
P	Prefix of return command with check	
&	Function sign of command “add”	
RING(cr)(lf)	Modem request handshake command	ATA(CR)(lf)
OK(cr)	Modem answer signal	No output
	TF1100 request handshake signal	AT(CR)(lf)

**Note:**

- 0). ( cr ) express carriage return, “enter”, its ASCII value is 0DH.(lf) expresses line feed, its ASCII value is 0AH.
- 1). ”d” expresses 0~9 digit numbers, 0 value is expressed as +0.000000E+00
- 2). ”d” stands for 0~9 digit numbers , there is no decimal point in integral part before “E”.
- 3). The run status of the TF1100 is expressed by 1~6 letters, for example “R”, “I”, ”H”
- 4). ”s” expresses ON or OFF or UD, For example “TR:ON,RL:ON” expresses that OCT and Relay are in actuated status;  
“TR:UD,RL:UD” expresses OCT and Relay are not actuated.
- 5). “@” expresses key value, for example 30H,expresses“0” key; command “M4”is equivalent to pressing key“4”.
- 6). “a” expresses current value, the value range is 0~20, for example AO2.34567, AO0.2
- 7). Eight “ddddddd” express electronic serial number of the TF1100. “t” expresses the type of the TF1100.
- 8) If there are multiple TF1100 flowmeters in a data network then the basic commands cannot be used alone. The prefix N or W must be added. Otherwise, multiple flowmeters will answer simultaneously, which will causes chaos in the system.

**3.3 Function prefix and function sign**

## (1) Prefix P

The character P could add before every basic command. That means the transferred data has CRC verify. The method of counting the verified sum is gained by binary system addition.

For example: Command DI+(CR)(the relative binary system data is 44H, 49H, 2BH, 0DH) transferred data is +1234567E+0m3. (CR)(the relative binary system data is 2BH, 31H, 32H, 33H, 34H, 35H, 36H, 37H, 45H, 2BH, 30H, 6DH, 33H, 20H, 0DH, 0AH). And command PDI +(CR) transferred data is +1234567E+0m3!F7(CR), “!” means the character before it is the sum character, and the verified sum of the two bytes after it is (2BH+31H+32H +33H +34H +35H +36H +37H +45H +2BH + 30H +6DH +33H +20H = (2) F7H)

**Note:** there could be no data before “!”, and also may be blank character.

## (2) Prefix W

Usage of Prefix W: W+ numeric string address code +basic command. Value range of the numeric string is 0~65535, except 13 (0DH carriage return), 10(0AH line feed), 42(2AH\*) and 38(26H&). If the instantaneous velocity of No.12345 flowmeter is to be accessed, the command W12345DV(CR) can use issued. Corresponding binary code is 57H, 31H, 32H, 33H, 34H, 35H, 44H, 56H and 0DH

### (3) Function sign &

Function sign & can add up to 6 basic commands (Prefix P is allowed) together to form a compound command sent to the flowmeter together. The flowmeter will answer simultaneously. For example, if No.4321 flowmeter is requested to simultaneously return: 1) instantaneous flow(flow rate), 2) instantaneous velocity, 3) positive total flow, 4) total heat flow, 5) AI1 analogous input current value and, 6) AI2 analogous input current value with check, the following command is issued;

W4321PDQD&PDV&PDI+&PDIE&PBA1&PAI2(CR)

Simultaneously returned data are likely as follows;

+0.000000E+00m<sup>3</sup>/d!AC(CR)

+0.000000E+00m/s!88(CR)

+1234567E+0m<sup>3</sup>!F7(CR)

+0.000000E+0GJ!DA(CR)

+7.838879E+00mA!59

+3.911033E+01!8E(CR)

## 4. RS485 COMMUNICATION PROTOCOL AND THE USE

On mainboard, there are two Communications short-circuit piece, plug them to RS485 position.

The baud rate of asynchronous communication (Primary station: computer system; Secondary station: ultrasonic flowmeter) is generally 9600bit/s. A single byte data format (10 bits): one start bit, one stop bit and 8 data bits. Check bit: none.

Connect the "RS485 A B" two wiring terminals from mainboard to PC.

### 4.1 Protocol Select

TF1100 series flowmeter can't support protocol 0 and protocol 1 at the same time, in Menu +6, select protocol 0 or protocol 1.

**When use RS485 for communication, select protocol 1 in menu +6.**

### 4.2 Communication commands

**4.2.1 Asynchronous communication** (Master station: computer system; Slave station: ultrasonic flow meter).

#### 4.2.2 Baud rate is usually 9600 bit/s.

#### 4.2.3 Single byte data format (10 bit)

4.1.3.1 start code: one bit.

4.1.3.2 stop code: one bit.

4.1.3.3 redundancy check code: no redundancy check.

4.1.3.4 digital codes: eight bits.

#### 4.2.4 Gating Signal of Master station

##### 4.2.4.1 Format of Gating Signal

*	Slave station NO.	Command from Master Station to Slave Station
①	②	③

① \* is start code(ASCII code 2A).

② Slave station NO., 000-999(send 3 bytes ASCII code). 0 can't be omitted.

③ Command From Master station to Slave station. There are 7 formats(0-6, send single byte ASCII code).

Command 0: obtain flow rate and total flow of Slave station.

Command 1: obtain flow velocity and total flow of Slave station.

Command 2: obtain positive and negative total flow of Slave station.

Command 3: obtain total working time of Slave station.

Command 4: obtain signal strength and signal quality of Slave station.

Command 5: clear total flow of Slave station

Command 6: clear total working time of Slave station

**4.2.4.2** For example: \*            189            0

It should be send: start code: 2A.

Slave station NO.: 31, 38, 39.

Command: 30.

## 4.2.5 Answer Signal of Slave Station

### 4.2.5.1 Answer Signal format for Master station Command 0

Command and symbol	flow rate	total flow	redundancy check bits
①	②	③	④

① Command and symbol: 2 bytes, the first byte is Master station command 0; the second byte is flow rate symbol(0 means positive and 1 means negative).

② Flow rate: 8 bytes (ASCII code) , the seventh and eighth bytes are fractional part.

③ Total flow: 12 bytes (ASCII code) , the eleventh and twelfth bytes are fractional part.

④ Redundancy check bits: 2 bytes (ASCII code) , it is the accumulative sum of former 22 bytes(with decimal additions accumulated) as redundancy check code in transmission process.

For example: Master station Command 0, flow rate symbol is positive, flow rate value is 367.89m<sup>3</sup>/h, total flow is 16745.78m<sup>3</sup>, it should send 30, 30, 30, 30, 30, 33, 36, 37, 38, 39, 30, 30, 30, 30, 30, 31, 36, 37, 34, 35, 37, 38, 33, 31.

Note: accumulative sum is 31(should send 33, 31).

### 4.2.5.2 Answer Signal format for Master station Command 1

Command and symbol	flow rate	total flow	redundancy check bits
①	②	③	④

① Command and symbol: 2 bytes, the first byte is Master station command 1; the second byte is flow rate symbol(0 means positive and 1 means negative).

② flow rate: 8 bytes (ASCII code) , the fifth, sixth, seventh and eighth bytes are fractional part.

③ total flow: 12 bytes (ASCII code) , the eleventh and twelfth bytes are fractional part.

④ redundancy check bits: 2 bytes (ASCII code) , it is the accumulative sum of former 22 bytes(with decimal additions accumulated) as redundancy check code in transmission process.

For example: Master station Command 1, flow rate symbol is positive, flow velocity value is 3.6859m/s, total flow is 16745.78m<sup>3</sup>, it should send 31, 30, 30, 30, 30, 33, 36, 38, 35, 39, 30, 30, 30, 30, 30, 30, 31, 36, 37, 34, 35, 37, 38, 33, 30.

Note: accumulative sum is 30(should send 33, 30).

### 4.2.5.3 Answer Signal format for Master station Command 2

Command and symbol	positive total flow	negative total flow	redundancy check bits
①	②	③	④

① Command and symbol: 2 bytes, the first byte is Master station command 2; the second byte is insignificant (random 0 or 1).

② Positive total flow: 12 bytes (ASCII code) , the eleventh and twelfth bytes are fractional part.

③ Total flow: 12 bytes (ASCII code) , the eleventh and twelfth bytes are fractional part.

④ Redundancy check bits: 2 bytes (ASCII code) , it is the accumulative sum of former 26 bytes(with decimal additions accumulated) as redundancy check code in transmission process.

For example: Master station Command 2, positive total flow is 14368.59m<sup>3</sup>, it should send 32, 30, 30, 30, 30, 30, 30, 30, 31, 34, 33, 36, 38, 35, 39, 30, 30, 30, 30, 30, 31, 36, 37, 34, 35, 37, 38, 32, 39.

Note: accumulative sum is 29(should send 32, 39).

### 4.2.5.4 Answer Signal format for Master station Command 3

Command and symbol	total working time	redundancy check bits
①	②	③

① Command and symbol: 2 bytes, the first byte is Master station command 3; the second byte is insignificant (random 0 or 1).

② Total working time: 8 bytes (ASCII code) , unit is minute.

③ Redundancy check bits: 2 bytes (ASCII code) , it is the accumulative sum of former 10 bytes(with decimal additions accumulated) as redundancy check code in transmission process.

For example: Master station Command 2, total working time is 4368 minutes, it should send 33, 30, 30, 30, 30, 30, 34, 33, 36, 38, 32, 34.

Note: accumulative sum is 24(should send 32, 34).

### 4.2.5.5 Answer Signal format for Master station Command 4

Command and symbol	signal strength and signal quality	redundancy check bits
①	②	③

① Command and symbol: 2 bytes, the first byte is Master station command 4; the second byte is insignificant (random 0 or 1).

② Signal strength and signal quality: 8 bytes (ASCII code), signal strength value is 4 bytes, the last byte is fractional part.

③ Redundancy check bits: 2 bytes (ASCII code), it is the accumulative sum of former 10 bytes(with decimal additions accumulated) as redundancy check code in transmission process.

For example: Master station Command 4, signal strength is 88.9, signal quality is 17.8, it should send 34, 30, 30, 38, 38, 39, 30, 31, 37, 38, 34, 35.

Note: accumulative sum is 45(should send 34, 35).

#### 4.2.5.6 Answer Signal format for Master station Command 5

Command and symbol	redundancy check bits
①	②

① Command and symbol: 2 bytes, the first byte is Master station command 5; the second byte is insignificant (random 0 or 1).

② redundancy check bits: 2 bytes (ASCII code), it is the accumulative sum of former 2 bytes(with decimal additions accumulated) as redundancy check code in transmission process.

This command is used for clearing total flow of Slave station.

For example: Master station Command 5, it should send 35, 30, 36, 35.

Note: accumulative sum is 65(should send 36, 35).

#### 4.2.5.7 Answer Signal format for Master station Command 6

Command and symbol	redundancy check bits
①	②

① Command and symbol: 2 bytes, the first byte is Master station command 6; the second byte is insignificant (random 0 or 1).

② Redundancy check bits: 2 bytes (ASCII code), it is the accumulative sum of former 2 bytes(with decimal additions accumulated) as redundancy check code in transmission process.

This command is used for clearing total working time of Slave station.

For example: Master station Command 6, it should send 36, 30, 36, 36.

Note: accumulative sum is 66(should send 36, 36).

## 5. KEY CODE

In a network environment, a key code is used to simulate the use of keys at the host device. For example, the instruction “M1” is input through the serial port, which is equivalent to pressing Key 1 on the keyboard of the TF1100 ultrasonic flowmeter. Thus all functions of key operation can be completely implemented at the host device. All key codes are shown in Table A-2.

**Table A-2 Key Codes**

key	Code of key(Hexadecimal system)	Code of key(Decimal system)	ASC II
0	30H	48	0
1	31H	49	1
2	32H	50	2
3	33H	51	3
4	34H	52	4
5	35H	53	5
6	36H	54	6
7	37H	55	7
8	38H	56	8
9	39H	57	9
.	3AH	58	:
<	3BH(0BH)	59	;
MENU	3CH(0CH)	60	<
ENT	3DH(0DH)	61	=
^/+	3EH	62	>
√/-	3FH	63	?



## APPENDIX 5 MODBUS-RTU COMMUNICATIONS PROTOCOL

**When use Modbus-RTU protocol, please refer to the following steps:**

1. Connect output terminal “D+, D-” to RS485 “A, B”.
2. Enter Menu 50, select the output off.
3. Enter Menu 46, enter the meter address, and this address must be the same with modbus address. If users modify the meter address after power on meter, please restart meter.
4. Enter Menu 52, select RS232C.
5. Enter Menu 62, select RS232C 9600 None.
6. The corresponding Modbus address.

Address	Length	Function	RS232 Command
(40001)	0	Return Flow rate per day	DQD
(40003)	2	Return Flow rate per hour	DQH
(40005)	4	Return Flow rate per minute	DQM
(40007)	6	Return Flow rate per second	DQS
(40009)	8	Return Flow velocity	DV
(40011)	10	Return Positive totalizer	DI+
(40013)	12	Return Negative totalizer	DI-
(40015)	14	Return Net totalizer	DIN
(40017)	16	Return Positive Heat totalizer	DIE
(40019)	18	Return heat flow rate per second	E
(40021)	20	Return percentage of Analog Output	DS
(40023)	30	Return T1 value (0~20mA)	BA1
(40025)	32	Return T2 value (0~20mA)	BA2
(40027)	34	No used	BA3
(40029)	36	No used	BA4
(40031)	38	Return T1 input value	AI1
(40033)	40	Return T2 input value	AI2
(40035)	42	No used	AI3
(40037)	44	No used	AI4
(40039)	48	Return meter address	DID
(40041)	50	Return TF1100 Electronic Serial Number (ESN)	ESN

**Note: The data format of DI+, DI-, DIN, DIE, DID and ESN is long integer data format, high bit is before low bit, the highest bit is symbol bit. The other's data format is IEEE754 floating-point data format, high bit is before low bit.**

## APPENDIX 6 Data Logger and Analyse Software Usage

### Meter Setting Before Using Data Logger

Before using the data logger, please check the following items of meter settings (otherwise, the data logger will not work normally):

**I. In Menu 60, it is time setup for meter, the format should be:**

YY-MM-DD (For example, it is Aug 14, 2015 today, the

Menu 60 setting should be 15-08-14)

HH-MM-SS (Hour-minute-second, in 24 hour format)

M60  
Date 15-08-14  
Time 15:16:46

**II. In Menu 50**

**Select**

**Logger Options**

**ON**

M50  
Logger Options  
ON

**III. Menu51, you setup start time (later than Menu 60 time, had better at least later 2 minutes), or setting up start time as: Start \*\*:\*\*:\*\* is also Okay.**

M51 Logger Setup  
Start 15:20:00  
Intervl 00:00:05  
Go On \*\*:\*\*:\*\*

**or**

M51 Logger Setup  
Start \*\*:\*\*:\*\*  
Intervl 00:00:05  
Go On \*\*:\*\*:\*\*

**IV. Menu 52,**

**Select**

**0. To RS-232**

M52  
Data Output  
0. To RS-232

**V. Menu 62**

**Select**

**Baudrate: =9600**

**Parity: None**

M62  
RS-232C Setup  
Baudrate: =9600  
Parity: None

Then insert the Data Logger module. The meter will restart, which means the data logger works well.

**IMPORTANT:** Restart the meter is a must before data logger working. Only insert the SD card the meter will not restart, and the data logger will **stop recording data**.

### 5.6.3 Read Data

When downloading data, it will create a new .csv file named for date,, the naming rules of

the file is the data storage date. For example,

### Naming rules of “csv” file

xx( year)-xx(month)-xx(date).csv

16-03-25.CSV

Save another file by naming rules when the “csv” file has recorded 2000 data.

(Default data number: without limit, according to requirement, the number can change, please consult factory)

When opening the “csv” file, the data are shown as below:

	A	B	C	D	E	F	G	H	I	J	K	L	M	N	O	P	Q	R	S
1	Date	TimeStamp	Flow	unit Vel	unit NET	uint	POS	unit	NEC	unit	EFR	unit	E.T	unit	Tin[°C]	Tout[°C]	T.D		
2	2016/3/25	15:15:29	4.56328	1/s	0.491558	m/s	4	m3	4	m3	0	m3	224.73	KW	13000	KWh	32.2996	20.3649	11.9347
3	2016/3/25	15:16:29	4.56521	1/s	0.492846	m/s	4	m3	4	m3	0	m3	225.011	KW	13000	KWh	32.2909	20.3649	11.926
4	2016/3/25	15:17:29	4.5783	1/s	0.494259	m/s	4	m3	4	m3	0	m3	226.186	KW	14000	KWh	32.2996	20.3432	11.9564
5	2016/3/25	15:18:29	4.57987	1/s	0.494428	m/s	4	m3	4	m3	0	m3	226.621	KW	14000	KWh	32.317	20.3693	11.9477
6	2016/3/25	15:19:29	4.5675	1/s	0.493094	m/s	4	m3	4	m3	0	m3	227.538	KW	14000	KWh	32.3474	20.3083	12.0391
7	2016/3/25	15:20:29	4.58037	1/s	0.494483	m/s	4	m3	4	m3	0	m3	227.607	KW	14000	KWh	32.33	20.304	12.026
8	2016/3/25	15:22:29	4.574	1/s	0.493795	m/s	4	m3	4	m3	0	m3	228.147	KW	15000	KWh	32.3561	20.2996	12.0565
9	2016/3/25	15:23:29	4.57332	1/s	0.493721	m/s	4	m3	4	m3	0	m3	228.762	KW	15000	KWh	32.3691	20.2953	12.0738
10	2016/3/25	15:25:29	4.54864	1/s	0.491057	m/s	4	m3	4	m3	0	m3	227.918	KW	15000	KWh	32.3822	20.2865	12.0957
11	2016/3/25	15:27:29	4.59105	1/s	0.495189	m/s	5	m3	5	m3	0	m3	228.944	KW	15000	KWh	32.3691	20.2996	12.0695
12	2016/3/25	15:29:29	4.56672	1/s	0.493009	m/s	5	m3	5	m3	0	m3	229.693	KW	16000	KWh	32.3822	20.2343	12.1479
13	2016/3/25	15:30:29	4.55305	1/s	0.491533	m/s	5	m3	5	m3	0	m3	229.352	KW	16000	KWh	32.4082	20.2343	12.1739
14	2016/3/25	15:32:29	4.55373	1/s	0.491851	m/s	5	m3	5	m3	0	m3	229.535	KW	16000	KWh	32.4082	20.2256	12.1826
15	2016/3/25	15:33:29	4.57246	1/s	0.493629	m/s	5	m3	5	m3	0	m3	229.567	KW	17000	KWh	32.3778	20.2299	12.1479
16	2016/3/25	15:34:29	4.5706	1/s	0.493428	m/s	5	m3	5	m3	0	m3	230.087	KW	17000	KWh	32.3822	20.2169	12.1653
17	2016/3/25	15:35:29	4.57454	1/s	0.492803	m/s	5	m3	5	m3	0	m3	229.41	KW	17000	KWh	32.3691	20.2169	12.1522
18	2016/3/25	15:36:29	4.56386	1/s	0.492701	m/s	5	m3	5	m3	0	m3	229.339	KW	17000	KWh	32.3865	20.2256	12.1609
19	2016/3/25	15:37:29	4.55195	1/s	0.491414	m/s	5	m3	5	m3	0	m3	229.255	KW	18000	KWh	32.3822	20.2038	12.1784
20	2016/3/25	15:38:29	4.55141	1/s	0.491356	m/s	5	m3	5	m3	0	m3	230.606	KW	18000	KWh	32.3908	20.1602	12.2306
21	2016/3/25	15:39:29	4.56454	1/s	0.492773	m/s	5	m3	5	m3	0	m3	230.489	KW	18000	KWh	32.3691	20.1602	12.2089
22	2016/3/25	15:40:29	4.55548	1/s	0.491795	m/s	5	m3	5	m3	0	m3	229.229	KW	18000	KWh	32.3517	20.1602	12.1915
23	2016/3/25	15:41:29	4.55682	1/s	0.491941	m/s	5	m3	5	m3	0	m3	229.7	KW	19000	KWh	32.3387	20.1602	12.1785
24	2016/3/25	15:43:29	4.56909	1/s	0.493265	m/s	5	m3	5	m3	0	m3	230.694	KW	19000	KWh	32.3257	20.1559	12.1698
25	2016/3/25	15:45:29	4.59885	1/s	0.496478	m/s	5	m3	5	m3	0	m3	230.498	KW	19000	KWh	32.2909	20.1515	12.1394
26	2016/3/25	15:46:29	4.59512	1/s	0.496373	m/s	5	m3	5	m3	0	m3	210.692	KW	20000	KWh	31.1876	20.1123	11.0753
27	2016/3/25	15:50:29	4.57622	1/s	0.494035	m/s	5	m3	5	m3	0	m3	188.603	KW	20000	KWh	30.0626	20.1036	9.959
28	2016/3/25	15:51:29	4.58291	1/s	0.494757	m/s	5	m3	5	m3	0	m3	174.672	KW	20000	KWh	29.2982	20.0862	9.212

Handheld can storage: data, time, flow, velocity, net totalizer, positive totalizer, and negative totalizer

Wall-mounted and portable flowmeter can storage: data, time, flow, velocity, net totalizer, positive totalizer, negative totalizer, EFR, E.T, Tin, Tout and T.D.



### Lanry Instruments (Shanghai) Co.,Ltd

Add: 6 Floor, Block F,Bldg 5,No.2800 Jiuxin Rd., Songjiang District, Shanghai 201612,China

Tel: 86 21-67801665,67618991

Fax: 86 21-67801625

<http://www.lanry-flow.com>